



ZBM000036ULT
8-2014

The Original

Dust Deputy®

AXD000009

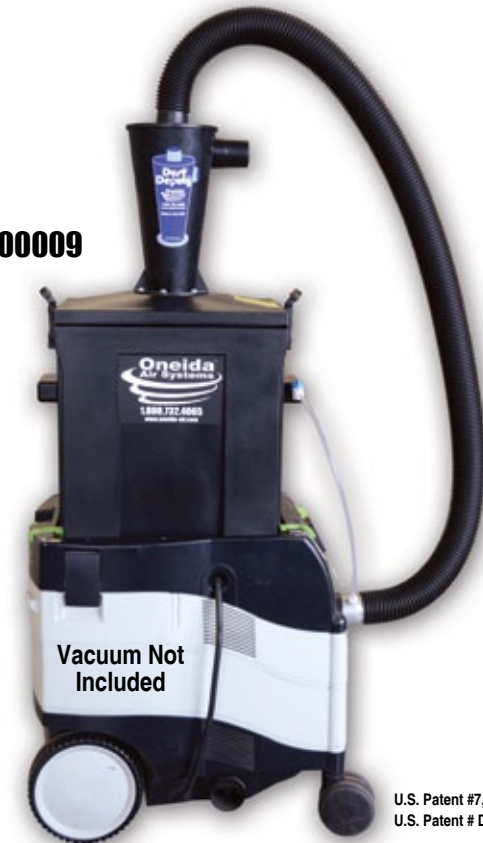

U.S. Patent #7,282,074
U.S. Patent # D668409

Regardless of where you purchased your Dust Deputy®, if you have any questions or issues with missing parts, damage or replacement issues, please call Oneida Air Systems first to let us help to resolve your problem! We fully stand behind our product and value our customers and want to do everything possible to make your purchase and experience with Oneida Air Systems a good one!

For Customer Service

M - F 8:30 - 5:00 pm EST

866 - 387 - 8822

customerservice@oneida-air.com

Ultimate Dust Deputy® Owner's Manual

1.800.732.4065 www.oneida-air.com

System Start-Up Information

Safety Instructions to be Strictly Followed.

Read the installation and maintenance instructions as well as the recommended safety practices in this manual and your shop vacuum's owner's manual before assembling and using the Dust Deputy®.

- ▶ Do not vacuum anything that is burning or smoking, such as cigarettes, matches, or hot ashes **or any hot substance!**
- ▶ Do not vacuum, or use this Dust Deputy® near flammable or combustible liquids, gases, or explosive dusts, such as gasoline or other fuels, lighter fluid, cleaners, oil-based paints, natural gas, hydrogen, coal dust, magnesium dust, grain dust, aluminum dust, sugar dust, flour dust or gun powder.
- ▶ To reduce the risk of health hazards from vapors or dusts, do not vacuum toxic materials unless a HEPA filter is used. Do not use or store near hazardous materials.
- ▶ The Dust Deputy® is made from static dissipating plastic. Additional grounding is recommended for increased safety. See grounding instructions.
- ▶ Wood dust mixtures are highly flammable and can be explosive. **NEVER** introduce sparks or sources of ignition into collector.
 - 1.) Dump drum after each use.
 - 2.) Ground system. (See pg. 9) For added safety.
- ▶ **NEVER leave wood dust in a building or vehicle.**
- ▶ Keep fire extinguishers handy at all times.
- ▶ Can be used for collecting non-flammable liquids.
- ▶ **Always read your shop vacuum owner's manual for safety procedures regarding the operation of your shop vacuum.**
- ▶ Dispose of waste in a **FIRE SAFE AREA.**

WARNING / SAFETY

Some dusts are highly flammable or explosive. Learn / know what you are dealing with. Follow all local, state, federal & NFPA codes and guide lines.

1.

Terms & Conditions

Oneida Air Systems makes every effort to accurately represent our products and prices, however OAS reserves the right to make changes to products and prices at any time. As a manufacturer, OAS reserves the right to change product specifications at any time in an effort to achieve better quality products.

Fire Hazards and Codes

Warning! Explosion and fire hazard! Never vacuum flammable fluids or gas, oil, alcohol, solvents, etc. Do not operate near flammable fluids or gas. Never vacuum warm fluids or materials at more than 140 deg. F (60 deg. C), such as burning cigarettes, ashes, glowing coals, etc.
Warning! Do not vacuum hazardous / carcinogenic dust unless a HEPA filter is installed. Always keep filter cartridge clean so the vacuum operates properly. Empty Dust Deputy waste can frequently. Never leave flammable material in your Dust Deputy or shop vacuum.

Returned Goods Policy

Buyer must inform O.A.S. of any shortage or damage, by so noting in writing, on the freight delivery bill prior to signing to indicate receipt of shipment. All claims, including claims covered under the limited warranty, are subject to inspection and investigation by O.A.S. O.A.S. reserves the right to inspect, investigate all returned products before Buyer's claim is settled. All products returned for a cash refund must be unused, resaleable and purchased within 30 days. There are no refunds on flex hose, custom made components or partial kit items. Kits must be returned in full (all components) for credit. **There will be a 25% restocking fee applied to any returned items. Buyer must call and get an RMA (Return Authorization Number). Merchandise must be shipped to us prepaid.**

Limited Warranty

Oneida Air Systems™ warrants the products manufactured by Oneida Air Systems, for a period of 90 days or more depending on the product, to the original purchaser from the date of purchase unless otherwise specified. Purchaser is responsible for returning warranty items to OAS at their expense. All parts must be returned with an OAS provided Returned Material Authorization Number (RMA#). Any shipment without an RMA will be refused. Items not manufactured by Oneida Air Systems are limited to their own manufacturer's warranties. All electrical items such as magnetic starters, remotes, sensors, pumps and accessories are limited to 90 days. Oneida Air Systems warrants that the product will be free from defects in materials and workmanship. This warranty does not apply to defects due directly or indirectly to misuse, negligence, accidents, abuse, repairs, alterations, improper wiring or lack of maintenance. This is Oneida Air Systems sole written warranty and any and all warranties that may be implied by law, including any merchantability or fitness, for any particular purpose, are hereby limited to the duration of this written warranty. Oneida Air Systems does not warrant or represent that the merchandise complies with the provisions of any law or acts unless the manufacturer so warrants. In no event shall Oneida Air Systems' liability under this warranty exceed the purchase price paid for the product and any legal actions brought against Oneida Air Systems shall be tried in the State of New York, County of Onondaga.

ONEIDA AIR SYSTEMS SHALL IN NO EVENT BE LIABLE FOR DEATH, INJURIES TO PERSONS OR PROPERTY OR FOR INCIDENTAL, AND CONTINGENT, SPECIAL, OR CONSEQUENTIAL DAMAGES ARISING FROM THE USE OF OUR PRODUCT.

Before Purchasing or Installing a dust collection system the buyer is cautioned to do so in accordance with prescribed Federal, State, Local, OSHA, NFPA, and any other applicable codes or regulations relating to the type of dust(s) you are collecting.

SOME TYPES OF DUST UNDER CERTAIN CONDITIONS HAVE THE POTENTIAL TO BE EXPLOSIVE.

Oneida Air Systems is not responsible for how the dust collector is used or installed. Dusts with deflagration or explosion risks, such as wood dust, may require additional safety equipment including but not limited to; venting, spark detection, suppression systems, back draft dampers or may require installation in an outside location or in a protected area away from personnel. The customer assumes the responsibility for contacting their insurance underwriter with regard to specific engineering controls or application requirements. (We suggest you reference NFPA 664, 654 and 68 codes for more information) Oneida Air Dust Collection Systems may not be suitable for some applications and are not designed to be used in explosive atmospheres. **Oneida Air Systems equipment should only be installed and wired by a licensed electrician following all applicable local and national electrical codes.**

10.

Troubleshooting

- ▶ Dust Deputy® not separating well. (Only a tiny amount of dust should reach the vacuum.)

Air leak. Check cyclone flange / drum lid / barrel. Even small leaks will affect performance.

- ▶ Low air volume.

Vacuum filter clogged. Blockage in hose.

- ▶ Material swirls in cyclone and won't drop down into drum.

Air leak in bottom of cyclone / drum lid or dust drum.

Large, bulkier material might swirl. Restart or temporarily cut off air flow to drop material down.

- ▶ Hose connections not tight.

Due to the varied hose diameters, flexible couplers can be used. They are available at local hardware stores in the plumbing section. Ensure grounding.



To Prevent Hose Pull Off

The inlet and outlet of the Dust Deputy® are shouldered and tapered to adapt to a range of vac hose sizes. If on your model the friction fit isn't as tight as needed you can do the following:

- ▶ Use a hose clamp.
- ▶ Wrap the inlet and outlet of the Dust Deputy with a layer of electrical tape to increase the friction fit.
- ▶ Secure with a sheet metal screw.

Accessories



*Hose not included.

Hollow handle scraper attaches by hose to vacuum source and sucks debris through handle to container. Eliminates mess from scraping that usually falls to floor.



Viper Scraper™

Part #	Description
AXS001160	Viper Scraper™
YSS001160P	Extra Tungston Carbide Blade Set (3)
YSS006011P	Extra Angle steel blade set (3)

Plastic Bags

Part #	Description
AXD600300	Bag 16 x 14 x 36 1.5 mil



Maintaining Anti-Static Grounding Pathways

The inlet of Festool dust extractors incorporate a connection to the earth ground to provide a safe discharge pathway for static electricity that may be generated when wood dust moves through hose or plastic parts. This grounded inlet works in conjunction with anti-static hoses. Oneida wants to make certain that our Ultimate Dust Deputy customers understand that there is a grounding pathway that must be maintained.

Oneida has always used static dissipating components in the UDD. The UDD has been third-party tested to function as specified.

CAUTION! Disconnect vacuum from electrical source before any of the following tests are performed.

Oneida is recommending that our customers:

- Use only tested anti-static components. Non anti-static hoses, couplers or connectors could interrupt the anti-static pathway.
- Make certain that the ground plug in your house wall socket is properly wired and working.
 - The anti-static pathway relies on the ground plug in your outlet to be functional.
 - Do not use two-prong to three-prong adapters, extension cords without a ground prong, etc.
- Install the UDD per our instructions which will ensure the anti-static pathway is maintained.
- Verify continuity through the anti-static pathway.
 - Continuity can be checked using a multi-meter that reads in mega ohms (see diagram, acceptable values).
 - Check from end of hose to earth prong on electrical plug.
- Experiencing any static problems likely means the grounding path is interrupted. Be certain this is resolved using these instructions or call us for assistance.

This diagram shows the continuous ground from the grounded prong at the outlet to hose inlet that is required for the anti-static grounding pathway.

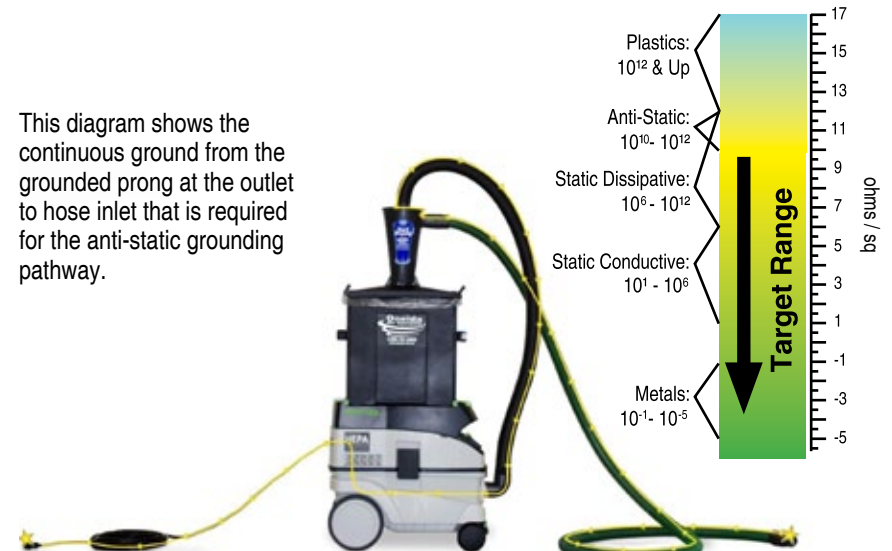

Ultimate Kit Contents Plastic Ultimate Dust Deputy® - AXD000009



- Hose 2"x 60" - AXD200060
- Cyclone Plastic - VXC110009
- Molded 9 Gal. Box - SDS090000
- Rubber Latch (2) - AFL000007
- Gasket for Cyclone - AXG000004
- Gasket Neoprene (4') - RGZ000000
- Foam Block - RMF000060
- Clamp Band - ACB320000
- Tubing 1/4" (3') - AXD600200
- Plastic Bags (3) - AXD600300
- Grounding Loop (2) - WGX000000
- Anti-Static Metal Tape (12") - VFA050015*
- SD Elbow - AXD600104
- Hardware - AHK000009
 - 1/4 - 20 x 3/4 Hex Head Bolt (6) - AFS015920
 - 10-32 x 1" Mach. Screw (4)

* - See pg. 8 for optional Anti-Static Tape use.

Dimensions

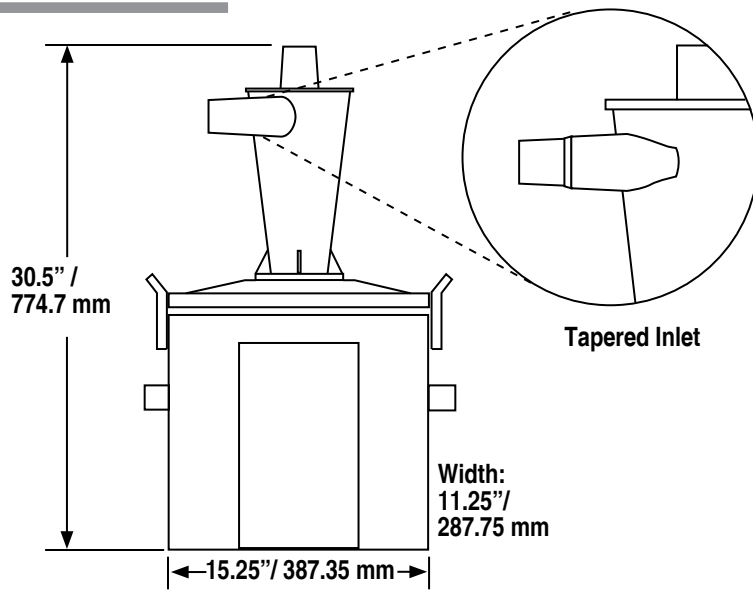

3.

Assembly Instructions (Cont.)

If hoses are not tight on the inlet, or keep pulling off, use the included clamp as shown below.

Hose Clamp



Make sure larger diameter hoses are pushed up so they fit tightly over the inlet

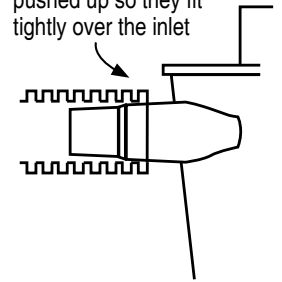

Accessories

We recommend always using static conductive hoses and components. If a non-conductive component is used, the ground pathway must be continued via conductive tape or wire to bridge the gap between the conductive components. By bridging this gap, the anti-static grounding pathway will be maintained.

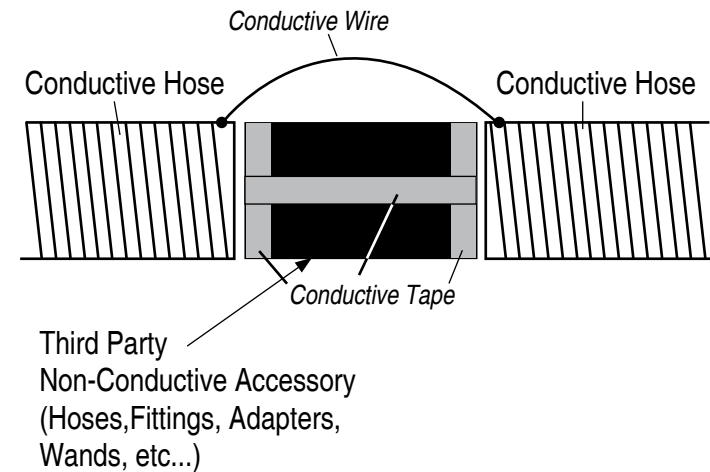

8.

Assembly Instructions (Cont.)

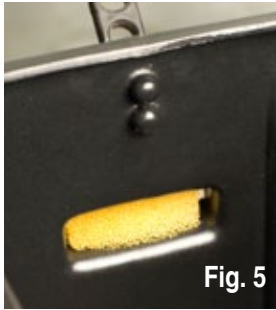

11. Place included filter into handle space of top valve inside of box. (Fig. 5) This prevents bag from being sucked into valve and prevents dust from entering valve if used without bag. (Light colored filter used for illustration purposes.)



12. Place bag into box, tucking into corners and folding top of bag over top of box. (Fig. 6)



13. Place top on box and latch down, attach your hoses to the Dust Deputy® inlet and outlet and you're ready to go! (Fig.7)

The UDD has the same footprint and fits onto the various models of Festool vacuums the same way the Systainer tool boxes do, because of that, on the Mini and Midi, the UDD will protrude beyond their perimeters like the Systainer does.



If you want to run the Dust Deputy® without the bag, you must shut the valve by turning the valve handle 90 degrees. The system must be air-tight to operate properly. Fig.8 shows valve in open position.

Note: Before resuming using plastic bags you must vacuum off the foam filter (Fig. 5) so air flow is not restricted.

7.

Assembly Instructions for Ultimate Dust Deputy® Kit

Translucent Dust Deputy used for illustration purposes only.

1. Put the top of the latch through the grounding loop as shown. 2. Then thread the loop from the back through the top hole in the latch. 3. Thread the loop back through the long hole in the latch so the terminal ends up behind the top screw hole. 4. Attach handle to box as shown.

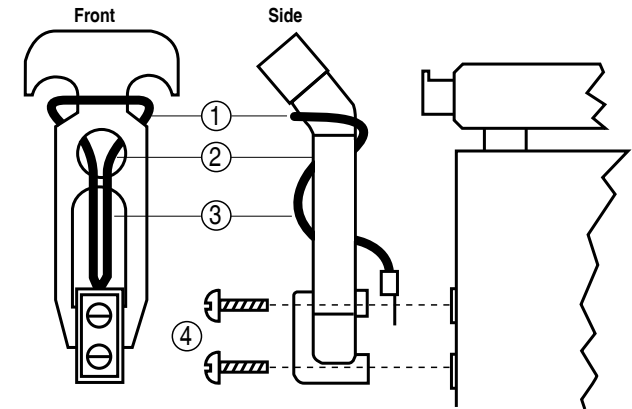

Note: It is important that the grounding loops be threaded through the latches in this way.



1. With a Phillips head screwdriver, attach the two rubber latches with grounding loops, one on either side of the dust collection box using the (4) 10 x 32 x 1" machine screws included in the hardware pack. Make sure that the handle of the latch curves downward when attached or when in the up position it points out.



2. Take the provided length of gasket, peel the protective backing off of the gasket and carefully place the gasket flat around the underside of the box top as shown, not on the side of the inside lid.



It is very important that there are no gaps in the gasket where the ends meet. Make sure they are butted together!

4.

Assembly Instructions (Cont.)



3. Put Gasket on box top making sure gasket holes line up with bolt holes in top.



4. With a Phillips head screwdriver, attach the Cyclone with the (6) provided 1/4"x 20 x 3/4" bolts. Tighten in a star pattern as shown. Do NOT over tighten.

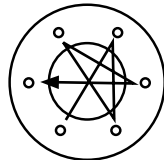

Point inlet at either latch.



5. Pull up latch with grounding loops so hole in latch goes over the pin / boss on Dust Box top.



6. Attach hose from vacuum to the top of the Dust Deputy® cyclone outlet.

Assembly Instructions (Cont.)

7. Attach SD Elbow with tube fitting to vacuum as shown in Fig. 2.

8. Push hose onto SD Elbow (Fig. 2A).

9. Push 1/4" tubing into tube fitting in SD Elbow. (Fig. 3)

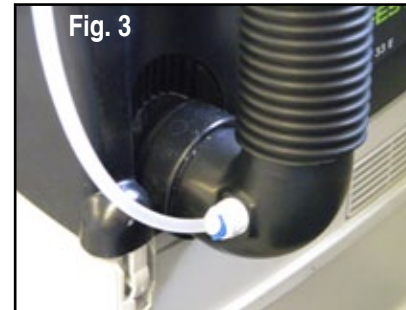

10. Push other end of tubing into 1/4" Valve Connector (Fig.4)

Tubing can be cut to desired length.

To remove tubing from valve, you must push end of valve in to release the grip. Ensure valve is open when using bags. Valve shown in open position.

