

## CS-D808/ CS-D1008

## Closed Loop Stepper Driver

**Closed Loop Stepper Driver  
Model CS-D808/ CS-D1008**

Digital Technology, max. 80/ 100 VDC, 8.0 A

**Product Description:**

Leadshine CS-D808/ CS-D1008 is a closed-loop stepper motor driver which is designed to solve the problem of step loss in open-loop stepper motor controllers and increasing system reliability with minimal cost. The CS-D808/ CS-D1008 implements Leadshine's advanced control algorithm based on their ten years of experience in stepper motor and servo control. The CS-D808/ CS-D1008 is highly reliable and competitively priced and is ideal for many industrial applications such as CNC, medical, electronics, packaging.

The CS-D808/ CS-D1008 can power 2-phase stepper motors with incremental encoders. Compared to conventional open-loop stepper motor systems, a closed-loop CS-D808/ CS-D1008 can eliminate possible step losses, perform real-time position error correction, and does not require torque reservation (100 % torque implementation). It operates the stepper motor with reduced heating, noise, vibration, etc.

**Features:**

- Closed-loop, eliminates loss of synchronization
- Enhance performance at low speed application (< 60 RPM)
- No torque reservation required for readjustment control
- No Tuning required for easy commissioning
- Supply voltage CS-D808: 30 - 80 VDC, CS-D1008: 30 - 100 VDC supply voltage,
- Output current of max. 8 A
- Pulse input frequency up to max. 200 kHz
- A configurable digital output for "In Target Position Range" signal, or as brake command signal
- Micro step resolution of 15 settings of 800 - 51,200 via DIP switches, or 200 - 51,200 via software (increments of 200)
- Protections for over voltage, over current and position error

**Electrical Specifications:**

Parameters	Min	Typ.	Max	Unit
Output current	0.5	-	8.0 (Peak)	A
Supply voltage CS-D808	+30		+80	VDC
Supply voltage CS-D1008	+30		+100	VDC
	+20	-	+80	VAC
Logic signal current	7	10	16	mA
Pulse input frequency	0	-	200	kHz
Minimal pulse width	2.5	-	-	µs
Minimal direction timing	5.0	-	-	µs
Insulation resistance	500			MΩ

**Environment:**

Cooling		Natural cooling or forced cooling
Operating Environment	Environment	Avoid dust, oil fog and corrosive gases
	Ambient Temperature	0 - 65 °C
	Humidity	40 - 90 % RH
	Operating	0 - 50 °C
	Vibration	10 - 50 Hz/ 0.15 mm
Storage Temperature		20 - 65 °C
Weight		Approx. 570 g

## CS-D808/ CS-D1008

## Closed Loop Stepper Driver

## Connector Configuration:

Control Signal Connector							
Pin	Name	I/O	Description				
1	PUL+	I	<u>Pulse signal:</u> (1) In single pulse control mode (step & direction) the input pulse signal is to be applied to this input (via software it is configurable whether the rising or falling edge triggers). (2) In double pulse control mode (CW/ CCW), set via PC software, this signal input represents a clockwise (CW) pulse and is active at both high voltage and low voltage level. (3) High voltage: 4.5 - 5 V / Low voltage: 0 - 0.5 V (also applies to DIR and ENA signals). (4) The pulse width should be set to 2.5 $\mu$ s or longer.				
2	PUL-	I					
3	DIR+	I	<u>Direction Signal:</u> (1). In single pulse mode (step & direction), the two directions of the motor are controlled via this input with low or high level (CW/ CCW). (2) In double pulse control mode (CW/ CCW), the input pulse signal is to be applied to this input, which controls the counterclockwise movement (CCW) with the levels High and Low. (3) The minimum setup time of the DIR signal should be at least 5 $\mu$ s. (4) The direction of rotation depends on the wiring of the motor/ drive. You can reverse the				
4	DIR-	I					
5	ENA+	I	<u>Enable signal:</u> This signal is used for enabling/disabling the driver. High voltage level of 4.5 - 24 V (NPN control signal) for enabling the drive and low voltage level of 0 - 0.5 VDC for disabling the driver). On the contrary please note that that PNP and Differential control signals with low voltage enable the drivers. By default, this signal is left <b>UNCONNECTED &amp; ENABLED</b> .				
6	ENA-	I					
Signal Connector							
Pin	Name	I/O	Description				
1	Pend+	O	<u>Configurable Digital Output Signal:</u> A configurable OC output signal. It takes a sinking or sourcing 20 mA current at 5 - 24 V. It can be configured as one of 2 types, IN POSITION (default), or BRAKE CONTROL via the Leadshine ProTuner CS-D software.				
2	Pend-	O					
1	ALM+	O	<u>Fault Signal:</u> An OC output signal which is active when one of the following error protections is activated: over-voltage, over-current, and position following error. This port can sink or source 20 mA current at 5 - 24 V. The resistance between ALM+ and ALM- is low impedance in normal operation and will change to high when the drive goes into error protection. The voltage active level of this fault output signal can be configured by configuration software.				
2	ALM-	O					
Encoder Feedback Connector							
Pin	Name	I/O	Description				
1	EB+	I	Encoder channel B+ input				
2	EB-	I	Encoder channel B- input				
3	EA+	I	Encoder channel A+ input				
4	EA-	I	Encoder channel A- input				
5	VCC	O	Encoder +5 V voltage output connection				
6	EGND	GND	Power ground connection				
Encoder Extension Cable Wire Out							
Wire	Color	Name	Description	Wire	Color	Name	Description
1	Red	VCC	+5 V power input	4	Blue	EA-	Encoder Channel A-
2	White	GND	GND	5	Yellow	EB+	Encoder Channel B+
3	Black	EA+	Encoder Channel A+	6	Green	EB-	Encoder Channel B-

- Notes:** (1) Shielding control signal wires are suggested  
 (2) to avoid/reduce interference, do not tie control signal cables and power wires together

# CS-D808/ CS-D1008

# Closed Loop Stepper Driver

Power and Motor Connector			
Pin	Name	I/O	CS-D808 Description
1	A+	O	Stepper motor A+ connection Connect motor A+ wire to this pin
2	A-	O	Stepper motor A- connection Connect motor A- wire to this pin
3	B+	O	Stepper motor B+ connection Connect motor B+ wire to this pin
4	B-	O	Stepper motor B- connection Connect motor B- wire to this pin
5	+V	I	Power supply positive connection 30 – 80 VDC power supply voltage
6	GND	GND	Power supply ground connection
CS-D1008 Description			
1	A+	O	Stepper motor A+ connection Connect motor A+ wire to this pin
2	A-	O	Stepper motor A- connection Connect motor A- wire to this pin
3	B+	O	Stepper motor B+ connection Connect motor B+ wire to this pin
4	B-	O	Stepper motor B- connection Connect motor B- wire to this pin
5	AC	I	Power supply connection 30 - 100 VDC or 20 - 70 VAC power supply voltage
6	AC	I	
RS232 Communication Port			
Pin	Name	I/O	Description
1	NC	-	Not connected
2	+5 V	O	+5 V power output
3	TxD	O	RS232 transmit
4	GND	GND	Ground
5	RxD	I	RS232 receive
6	NC	-	Not connected

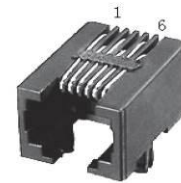

### Mechanical Specifications:

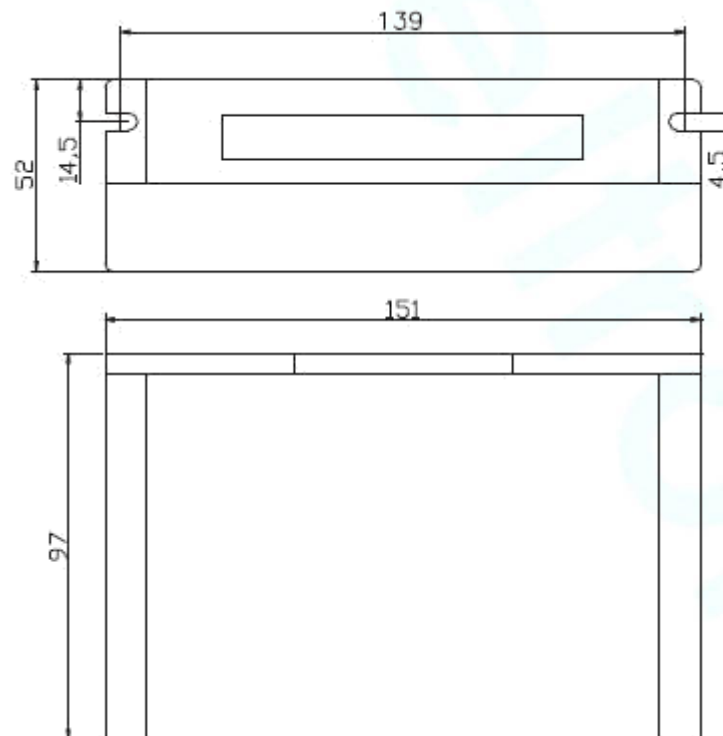

(unit: mm)

# CS-D808/ CS-D1008

# Closed Loop Stepper Driver

### Typical Connections:

A complete closed loop stepper system should include a stepper motor with encoder, CS-D808/ CS-D1008 driver, power supply and controller (pulse generator). A typical connection is illustrated.

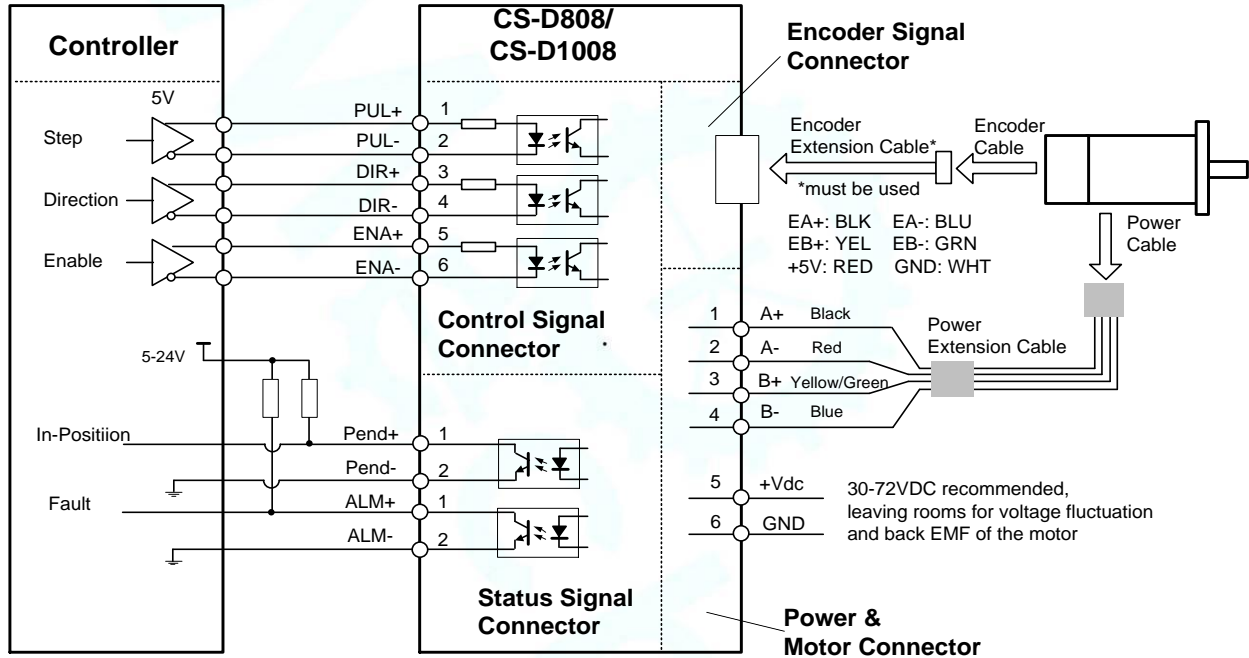

### Typical Control and Fault Output Connections:

The CS-D808/ CS-D1008 can accept differential and single-ended control signal inputs (open-collector and PNP output). A CS-D808/ CS-D1008 has 3 optically isolated control inputs, PUL, DIR, and ENA. Refer to the following two figures for connections of open-collector and PNP signals.

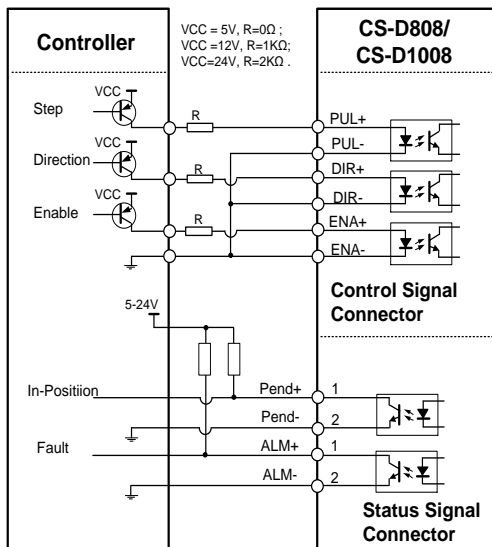

Connections to PNP signal (common-cathode)

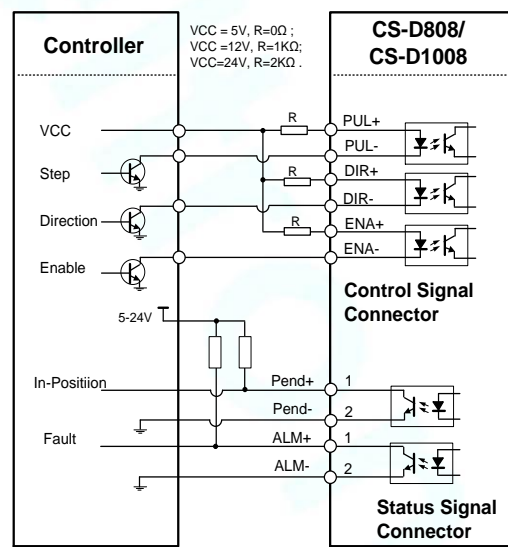

Connections to open-collector signal (common-anode)