

IMPORTANT: Read before using



Operating/Safety Instructions

Oscillating Tangential Knife OTK-3



Call for consumer information

Customers from outside the U.S.

STEEPCRAFT GmbH & Co. KG
An der Beile 2
58708 Menden
Germany
Phone: 0049-2373-179 11 60
E-mail: info@stepcraft-systems.com

Customers from the U.S. / Canada

STEEPCRAFT Inc.
59 Field Street, Rear Building
Torrington, CT, 06790
United States
Phone 001-203-5561856
E-mail info@stepcraft.us

Translation of the original Operating and
Safety Instructions

Date of: 12-01-2018

NOTICE

All instructions, warranties and other collateral documents are subject to change at the sole discretion of STEPCRAFT GmbH & Co. KG. For up-to date product literature, visit www.stepcraft.us for customers from North America and Mexico or www.stepcraft-systems.com for customers from the rest of the world and click on the service & support tab for this product.

Meaning of Special Language

The following terms are used throughout the product literature to indicate various levels of potential harm when operating this product: The purpose of safety symbols is to attract your attention to possible dangers. The safety symbols, and their explanations, deserve your careful attention and understanding. The safety warnings themselves do not eliminate any danger. The instructions or warnings they give are not substitutes for proper accident prevention measures.

NOTICE Procedures, which if not properly followed, create a possibility of physical property damage AND a little or no possibility of injury.

CAUTION Procedures, which if not properly followed, create a probability of physical property damage AND a possibility of serious injury.

WARNING Procedures, which if not properly followed, create a probability of property damage, collateral damage, serious injury or death OR create a high probability of superficial injury.



Safety Alert: Indicates caution or warning. Attention is required in order to avoid serious personal injury.



Read the ENTIRE instruction manual in order to become familiar with the features of the product and how to operate them. Failure to operate the product correctly can result in damage to the product, personal property and cause serious injury, electric shock and/or fire.

This product is designed for private use. It is also suited for sample production in the commercial sector. The product is developed for advanced craftsmen with previous experience in the operation of tools such as electric drills, routers and computerized tools like CNC routers or 3D printers. It must be operated with caution and common sense and requires some basic mechanical ability. Failure to operate this product in a safe and responsible manner could result in personal injury or damage to the product or other property. This product is not intended for use by children. Do not attempt disassembly, use with incompatible components or augment product in any way without the approval of STEPCRAFT GmbH & Co. KG or STEPCRAFT, Inc. This manual contains instructions for safety, operation and maintenance. It is essential to read and follow all the instructions and warnings in the manual, prior to assembly, setup or use, in order to operate correctly and avoid damage or serious injury.

Age Recommendation: For advanced handcrafters ages 14 and above. This is not a toy.

SAVE ALL WARNINGS AND INSTRUCTIONS FOR FUTURE REFERENCE.

Should you encounter any doubts or require any further information, please do not hesitate to contact us before commissioning of the power tool. Our contact details can be found on the front page of this manual.

The term “power tool” in the warnings refers to the wired power / signal supply and the Oscillating Tangential Knife hereafter referred to as “Tangential Knife”, “OTK-3” or “power tool”.

General Safety Warnings for the Use of Power Tools

Work Area Safety

NOTICE	Keep work area clean and well lit. Cluttered or dark areas invite accidents.
CAUTION	Do not operate power tools in explosive atmospheres, such as in the presence of flammable liquids, gases or dust. Power tools create sparks which may ignite dust or fumes.
NOTICE	Keep children and bystanders at a distance while operating a laser tool. Distractions can cause you to lose control and can result in accidents.

Electrical Safety

CAUTION	Power tool plugs must match the outlet. Never modify the plug in any way. Do not use any adapter plugs.
CAUTION	Do not expose power tools to damp, rain or wet conditions. The Tangential Knife is only suitable for indoor use.
CAUTION	Do not abuse the cord / hose. Never use the cord/hose for carrying, pulling or unplugging the power tool. Keep cord/hose away from heat, oil, sharp edges or moving parts. Damaged or entangled cords/hoses increase the risk of electric defects and malfunctions.

Personal Safety self-dependent

⚠ CAUTION	Stay alert, watch what you are doing and use common sense when operating the power tool. Do not use the power tool while you are tired and/or under the influence of drugs, alcohol or medication. A moment of inattention while operating the power tool may result in serious personal injury.
NOTICE	All persons who operate the power tool must have read and fully understood all relevant safety and operating instructions. Misunderstanding may result in personal injury.
⚠ CAUTION	Use personal protective equipment. Always wear eye protection and gloves. Protective equipment reduces the risk of personal injuries.
NOTICE	Prevent unintentional starting. Ensure the appliance switch is in the off-position (0) before connecting the power tool to the power supply respectively to the main board of the CNC router, picking it up or carrying the tool. Carrying power tools with your finger on the switch or energizing power tools with the switch on invites accidents.
NOTICE	Remove the Allen wrench before switching on the power tool. A tool left on an oscillating part of the power tool may result in personal injuries.
NOTICE	Keep proper footing and balance at all times. This enables better control of the power tool in unexpected situations.
NOTICE	Dress properly. Do not wear loose clothing or jewelry. Keep your hair, clothing and gloves away from oscillating parts so that they cannot be caught.

Power Tool Use and Care

NOTICE	Do not force the power tool. Use the correct power tool for your application. The correct power tool will do the job better and safer at the dedicated rate for which it was designed.
NOTICE	Do not use the power tool if the switch cannot be turned on and/or off. Any power tool that cannot be controlled with the switch is dangerous and must be repaired.
⚠ CAUTION	Disconnect the plug from the power source and/or the battery pack from the power tool before making any adjustments, changing accessories, or storing power tools. Such preventive safety measures reduce the risk of starting the power tool accidentally.
⚠ CAUTION	Store idle power tools out of the reach of children and do not allow persons unfamiliar with the power tool or these instructions to operate the power tool. Power tools are dangerous in the hands of untrained users.
NOTICE	Maintain the power tools. Check for misalignment or binding of moving parts, breakage of parts and any other conditions that may affect the power tool's operation. If damaged, have the power tool repaired before use. Many accidents are caused by poorly maintained power tools.
NOTICE	Keep the cutting tools sharp and clean. Well maintained cutting tools with sharp cutting edges get caught less and are easier to control via the machine.
NOTICE	Use the power tool, accessories and end mills etc. in accordance with these instructions, taking into account the working conditions and the work to be performed. Use of the power tool for operations different from those intended could result in a hazardous situation.

Service

NOTICE	Have your power tool serviced by a qualified repair person using only identical replacement parts. This will ensure that the safety of the power tool is maintained.
---------------	---

Safety Rules for Oscillating Parts

⚠ WARNING	Make sure that the power tool cannot cut its own hose, therefore never install the hose across the machine table. Cutting a "live" wire may lead to a short circuit destroying the electronics of the CNC system.
NOTICE	Use clamps or another practical and secure way to secure the workpiece on the machine table, e. g. with the help of a vacuum table, double-sided tape or clamps. Holding the workpiece with your hands leaves it unstable and may lead to loss of control.
NOTICE	Accessories must be rated for at least the speed recommended on the tool warning label. Accessories running over rated speed can fly apart and cause injury.
⚠ CAUTION	Always disconnect the power cord from the power source before making any adjustments or attaching any accessories. You may unexpectedly cause the tool to start leading to serious personal injury.
NOTICE	Be aware of the switch location, when placing the tool down or when picking the tool up. You may accidentally activate the switch.
NOTICE	Do not hold the Tangential Knife in your hands during the start-up. The reaction torque of the motor / the blade shaft can cause the power tool to twist during acceleration.
NOTICE	Always wear safety goggles and gloves. Using personal protective equipment and working in a safe environment reduces the risk of injury.

NOTICE	Make sure that the blade is securely clamped in the Weldon shaft after the blade has been exchanged or other changes have been made. Loose elements can shift unexpectedly and lead to a loss of control. Loose, oscillating parts will be hurled.
CAUTION	This is not a handheld tool. The Tangential Knife is designed to be system-guided and must be operated in STEPCRAFT CNC system or a comparable CNC router. Operation of the power tool handheld may result in serious personal injury.
NOTICE	Do not reach in the area of the oscillating blade. The proximity of the blade to your hand may not always be obvious.
NOTICE	Never clamp insertion tools other than solid-carbide blades with Weldon shaft into the Tangential Knife. Other insertion tool, such as brushes, can get loose or separate at high speeds and, thus, result in injuries.
NOTICE	Never use dull or damaged insertion tools. Sharp insertion tools must be handled with care. Damaged insertion tool can snap during use. Dull insertion tools require more force to push the tool through the material, possibly causing the insertion tool to break.
CAUTION	Use a vacuum table, double-sided tape or clamps to secure the workpiece. Never hold the workpiece with your hands.
NOTICE	Check your workpiece before cutting it. Make sure that it does not contain any nails or other objects. These can cause the insertion tool to break.
NOTICE	The correct feed rate, the number of strokes per minute and the immersion depth of the blade needs to be chosen carefully. Always adhere to the recommended speed and feed for the respective workpiece material. When in doubt, select lower cutting values and increase them by and by.
CAUTION	If the insertion tool becomes jammed or bogged down in the workpiece, turn the power tool "OFF" by the switch. Stop the CNC program or, alternatively, activate the emergency switch of the CNC system. Wait for all oscillating parts to stop and disconnect the power tool from the power source before working to free the jammed material. The tool switch still in the „ON“ position can lead to an unexpected restart that can cause serious injuries.
CAUTION	Do not touch the insertion tool after use. After usage, the blade can be too hot to be touched with bare hands.
NOTICE	Do not allow familiarity gained from frequent use of your Tangential Knife to become commonplace. Always remember that a careless fraction of a second is sufficient to inflict severe injury.
CAUTION	Do not alter or misuse tool. Any alteration or modification is a misuse and may result in serious personal injury.
CAUTION	When using oscillating blades, the workpiece has always to be securely clamped. Never attempt to hold the workpiece with your hands. The blade can get easily canted in the material which can cause a loss of control resulting in serious injury.

Safety Rules for System-guided Tools











CAUTION	The power tool has to be controlled by a control software of a CNC router. Therefore, the power supply of the power tool has to be properly connected to the external output of the main board of the CNC router via a 15-pin Sub-D cable. Prior to each commissioning of the power tool the ON/OFF, speed and emergency button functionality has to be checked. Malfunction may result in serious personal injury.
NOTICE	Do not leave a running CNC System and power tool unattended, turn power off. Only when a CNC router or power tool come to a complete stop and are disconnected from the mains are they safe.

Additional Safety Warnings

NOTICE	Depending on the application field of the machine (private or commercial), observe the applicable occupational safety and health, safety and accident prevention and environmental regulations, too.
NOTICE	Develop a periodic maintenance schedule for your tool. When cleaning a tool be careful not to disassemble any portion of the tool since internal wires may be misplaced or pinched or safety guard return springs may be improperly mounted. Certain cleaning agents such as gasoline, carbon tetrachloride, ammonia, etc. may damage the surface.
CAUTION	Risk of injury to user. The power cord must only be served by a STEPCRAFT service facility.
WARNING	Some dust created by cutting contains chemicals known to cause cancer, birth defects or other reproductive harm. Some examples of these chemicals are silicate minerals of asbestos boards. Your risk from exposures to these varies, depending on how often you perform this type of work. To reduce your exposure to these chemicals: work in a well-ventilated area, and work with approved safety equipment, such as those dust masks that are specially designed to filter out microscopic particles.

Symbols

IMPORTANT: Some of the following symbols may be used on your tool. Please study them and learn their meaning. Proper interpretation of these symbols will allow you to operate the tool better and safer.

Symbol	Name	Erklärung
V	Volts	Voltage (potential)
A	Amperes	Current
Hz	Hertz	Frequency (cycles per second)
W	Watt	Power
Kg	Kilograms	Weight
Min	Minutes	Time
S	Seconds	Time
mm	Length, Height, Width	Size in millimeter (metric)
inch	Length, Height, Width	Size in inch
∅	Diameter	Size of drill bits, end mills, etc.
.../min	Revolutions or reciprocation per minute	Revolutions, turns, etc. per minute
V→, V↓	Feed	Horizontal / vertical speed in millimeter per second
0	Display off position	Zero speed / revolution per minute
15, 45, 75, 99	Display selector settings	Speed / revolution per minute as percentage share of the max. speed / revolution. Higher number means greater speed. 99 equal the max. revolution per minute.
→	Arrow	Action in the direction of an arrow
	Warning symbol	Alerts user to warning messages
	CAUTION hot surface	Alerts user not to touch the surface - danger of burns
	CAUTION rotating tool	Alerts user not to touch the blade / the insertion tool - danger of lacerations
	Wear eye protection symbol	Alerts user to wear protective glasses
	Wear hand protection symbol	Alerts user to wear protective gloves
	Grounding symbol	Alerts user to ground the power tool / electrical system
	Wear ear protection symbol	Alerts user to wear a hearing protector
	Read manual symbol	Alerts user to read manual BEFORE first commissioning
	Unplug symbol	Alerts user to unplug the device BEFORE servicing the power tool
	Disposal symbol	Instructions for disposal of WEEE by users of the European Union

Content

1	General Instructions	8
1.1	Information and Explanations on the Operating Instructions.....	8
1.2	Description of Components	8
1.3	Intended Use.....	8
1.4	Safety Features.....	8
2	Design and Function of the Tangential Knife	9
3	Setup	10
3.1	WinPC-NC	10
3.2	UCCNC.....	16
3.3	Environmental Requirements	17
3.4	Emergency Stop.....	18
3.5	Optional Accessories.....	18
4	Operation of the Tangential Knife.....	18
4.1	Operator.....	18
4.2	Tangential Knife	18
4.3	CNC Router / Control Program.....	19
4.4	Emergency stop	19
4.5	Function Test	20
4.6	Testing the Emergency Stop Functionality	21
4.7	Cutting Recommendations	22
5	Exemplary CAM-CNC-Process.....	23
5.1	CAM with Vectric VCarve Pro.....	23
5.2	CNC with WinPC-NC.....	27
6	Technical Specifications	31
6.1	Power, Dimensions and Weight of the Tangential Knife	31
6.2	Pin Assignment of the Interface (15-pin D-Sub Input Signals)	31
7	Transport / Storage	31
7.1	Transport.....	31
7.2	Packaging	32
7.3	Storage	32
8	Maintenance Information.....	32

8.1	Service	32
8.2	Cleaning	32
8.3	Lubrication	33
9	Failure	33
9.1	Response to Malfunctions	33
10	Appendix.....	34
10.1	Warranty and Service Contact Information	34
10.2	Manufacturer	34
10.3	Identification Plate	34
10.4	Copyright.....	34
10.5	Limited Warranty	34
10.6	Disposal	36
10.7	RoHS, 2002/95/EG	36
10.8	EC-Declaration of Conformity	37

1 GENERAL INSTRUCTIONS

1.1 INFORMATION AND EXPLANATIONS ON THE OPERATING INSTRUCTIONS

Thank you for purchasing a STEPCRAFT Tangential Knife. This manual is intended to familiarize you with your STEPCRAFT Tangential Knife (hereafter referred to as OTK-3) and its control system, providing you with all the necessary information you will need in order to operate it safely and professionally.

	<p>WARNING Please read this manual thoroughly and carefully prior to the first use of your STEPCRAFT OTK-3. Operate the power tool and the CNC system only when you are sure that you have understood these instructions in their entirety. Hereby you minimize the risk of injury and / or prevent property damage.</p>
---	---

Should you encounter any doubts or require any further information, do not hesitate to contact us. Our contact information can be found on the front page of this manual.

Keep this manual always in close proximity to the STEPCRAFT OTK-3 for future reference.

We cannot be held accountable either for any kind of injury and / or property damage resulting from improper handling of the OTK-3 or from failure to follow the safety regulations properly (see page 2 cont.). We reserve the right to further develop the Tangential Knife as well as the controller.

1.2 DESCRIPTION OF COMPONENTS

The STEPCRAFT OTK-3 consists of Tangential Knife and a 15-pin D-Sub connecting cable. The Tangential Knife has a 43 mm tool neck and an active air cooling of the electronics.

The ready-to-use unit consists of the following components:

1. Tangential Knife
2. Connection cable D-Sub 15-pin male-female
3. Solid-carbide blades with Weldon shaft (accessories, see point 3.5 of this manual)
4. Special maintenance grease (2 g), KLUBER ISOFLEX NBU 15
5. Operating and safety instructions

1.3 INTENDED USE

The STEPCRAFT OTK-3 is an oscillating Tangential Knife for cuttable workpiece materials, such as soft and rigid foam, fabrics, leather, rubber, paper or cardboard. It has been developed for private users (e. g. model designers). In the commercial sector the OTK-3 is only suited for the occasional use as, for example, in the production of samples and prototypes. Basically, the OTK-3 has been designed for the usage with a CNC router but has been especially developed for the installation and connection with the STEPCRAFT machine series - Plug & Play.

1.4 SAFETY FEATURES

The OTK-3 complies with the relevant guidelines of the EU Machine Directive 2006/42/EG. It encompasses the following points:

- ON / OFF switch on the Tangential Knife
- Power / Signal cables with a safety device against unintended disconnection
- Connection to emergency stop signal at the machine which immediately stops the Tangential Knife

2 DESIGN AND FUNCTION OF THE TANGENTIAL KNIFE

<p>⚠ WARNING</p>	<p>Disconnect the OTK-3 from the power source before making any adjustments. Such preventive safety measures reduce the risk of starting the tool accidentally.</p>
	

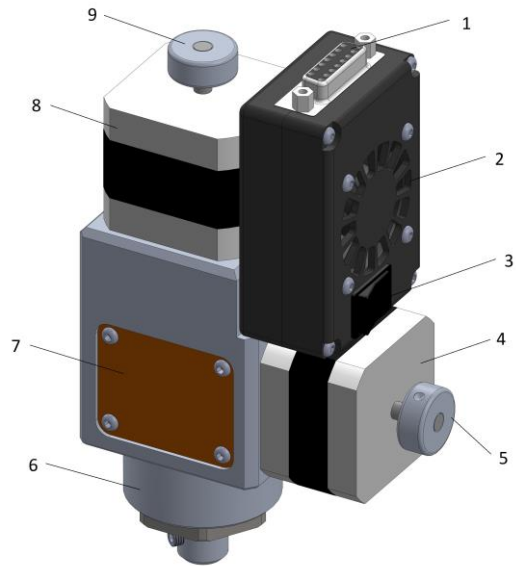

- 1 = D-Sub 15-pin connection
- 2 = Casing with integrated control electronics and passive cooling
- 3 = ON / OFF switch
- 4 = Motor for stroke movement
- 5 = Adjusting wheel for manual adjustment of the blade position (stroke height)
- 6 = Casing with 43 mm EURO tool neck
- 7 = Maintenance cover with type label
- 8 = Motor for blade positioning
- 9 = Adjusting wheel for manual adjustment of the blade position (direction)

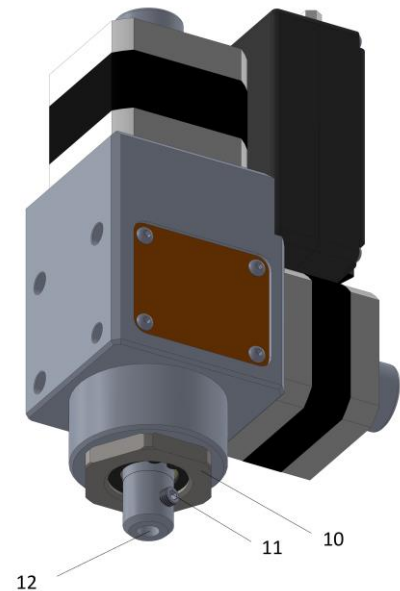

- 10 = Slide bearing retaining screw
- 11 = Stroke axis with threaded bolt for the fixation of the oscillating blade with Weldon shaft
- 12 = Opening for the oscillating blade



3 SETUP

 WARNING	Always turn off the ON / OFF switch before handling or configuring the Tangential Knife.
	

3.1 WINPC-NC

For the operation of the Tangential Knife, please install the most current version of WinPC-NC which is, as of this day, version 3.00/48.

For the effective and save commissioning of the Tangential Knife with WinPC-NC various parameters have to be set correctly.

/Basic Settings/Signal Wizard/

Pos.	Description	Input/Output WinPC-NC	Pinning	Inverted
1	OTK-3 reference switch	I238 Homing Switch 4	LPT1 Pin13	No
2	Number of strokes per minute (PWM)	O218 Sp.speed PWM	LPT1 Pin14	No
3	OTK-3 on/off	O242 Spindle on/off	LPT1 Pin1	No

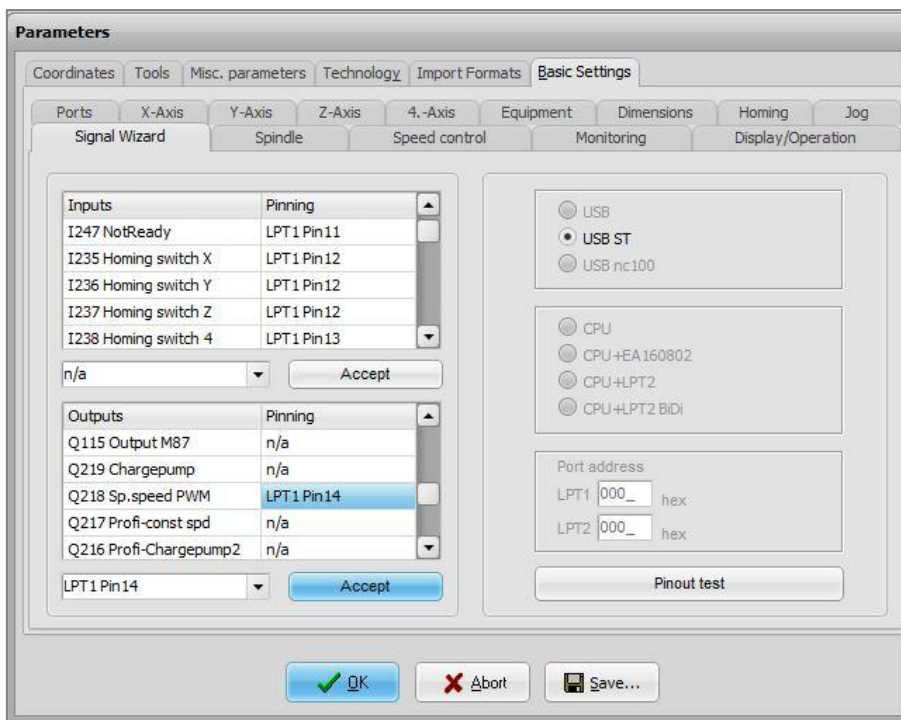

/Basic Settings/Equipment/

- Technology, Tangential cutting= active
- Others, 4th axis = active

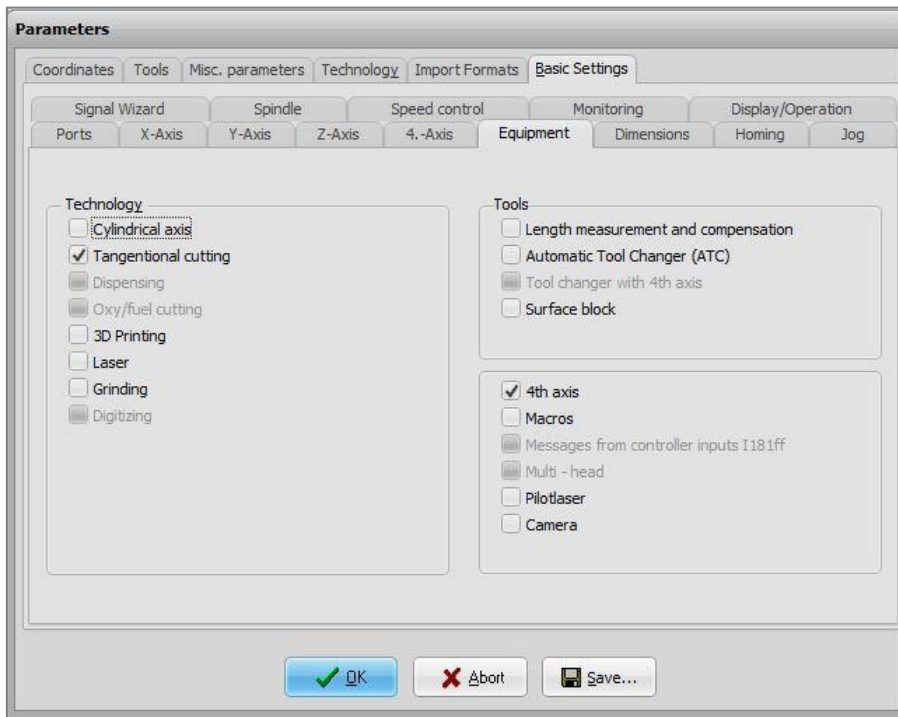

/Basic Settings/Homing/

Check all settings of the 4th axis:

- Homing switch at the end = neg.
- Homing offset = Is the value by which the oscillating blade is turned after homing is completed and equals the angle between the switch position of the reference switch and the A0 position, the workpiece zero point of the rotation axis. The selected CAM software defines the A0 position of the blade`s rotation axis. If the PLT or DXF data import of WinPC-NC is used for the processing of the tangential cut, the cutting direction resp. the screw connection (threaded bolt) of the Weldon connection on the A0 position has to point exactly in positive X-direction (see following illustration).

The angle measures approx. +240 degree.

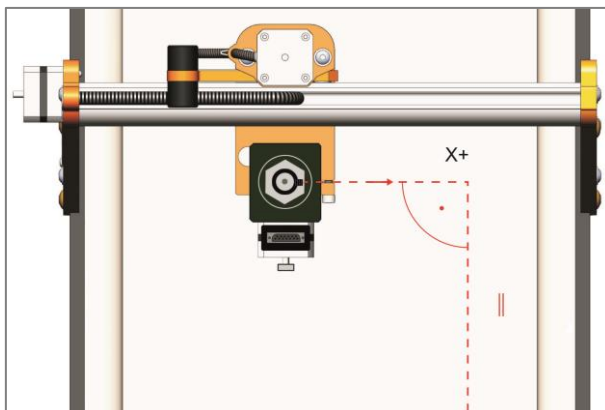

- Homing speed, search = 50.00 %/min
- Homing speed, search = 5.00 %/min
- Homing 4th axis = last

/Basic Settings/Spindle/

- Maximum spindle speed = 100 (equals 100 % of the PVM signal)
- Spindle speed default = 100
- Dwell time at spindle on (ms) = 2000

/Basic Settings/4.-Axis/

The motor for the blade positioning of the oscillating blade needs 3.200 steps for a 360° revolution.

- Axes resolution = 3200 steps/r
- Distance per revolution = 360 °/r
- Maximum speed = 360 °/min
- Maximum start / stop speed = 2 °/min
- Rapid speed = 0 °/min
- Shortest ramp = 100 ms
- Invert movement direction = Yes
- Backlash = 0
- Programmable as = A

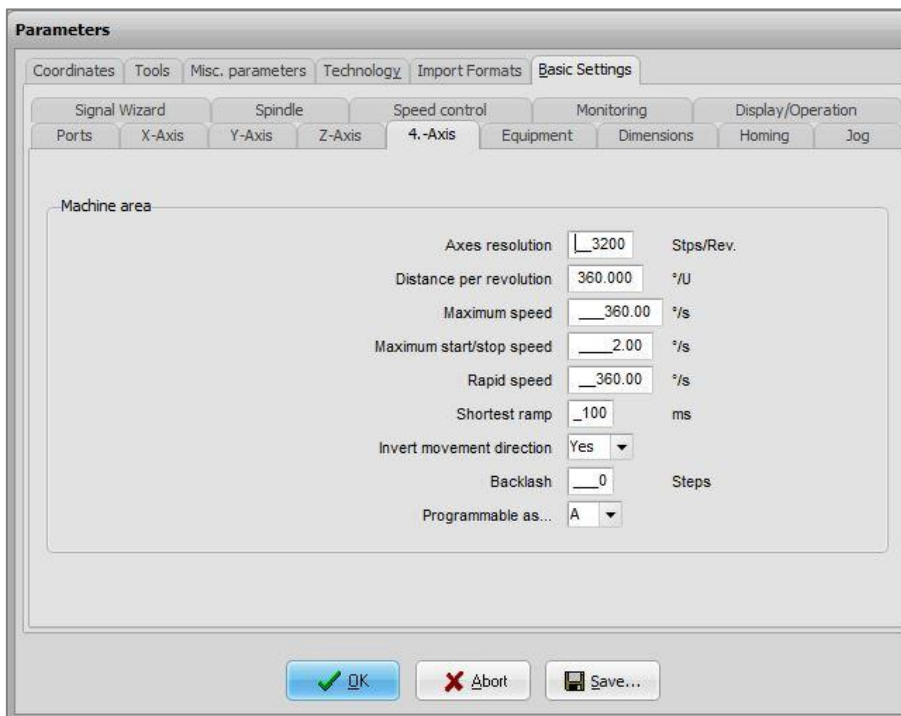

Parameters/Import Formats/

Check which units are preset. We recommend mm resp. mm/s.

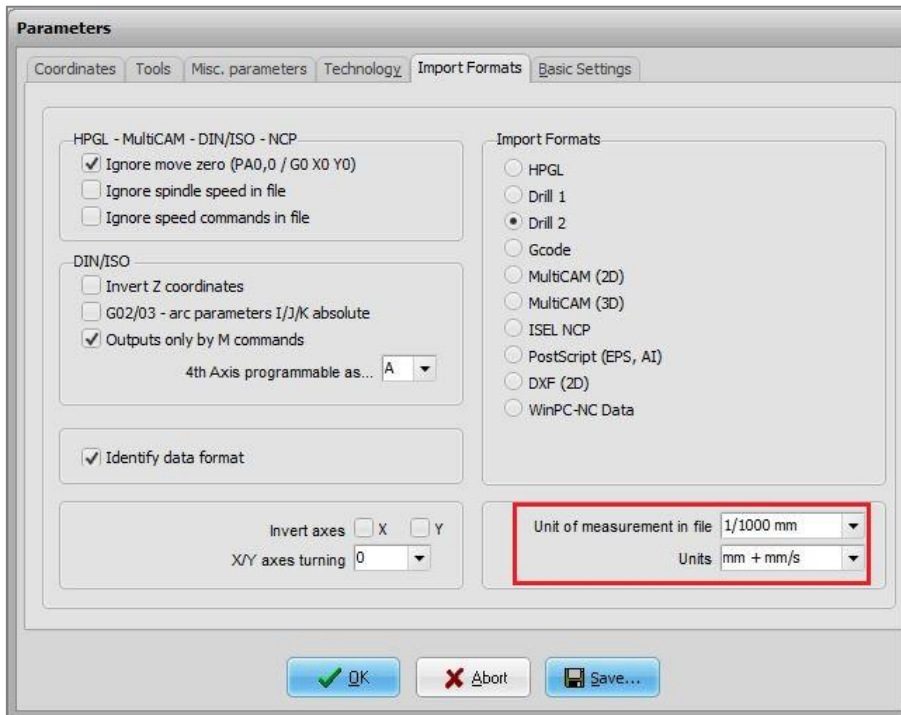

/Basic Settings/Speed control

Smooth outlines, factor = This value defines the combination of mini vectors in μm , a value of 300 corresponds to an accuracy of 0,3 mm and should suffice for cutting.

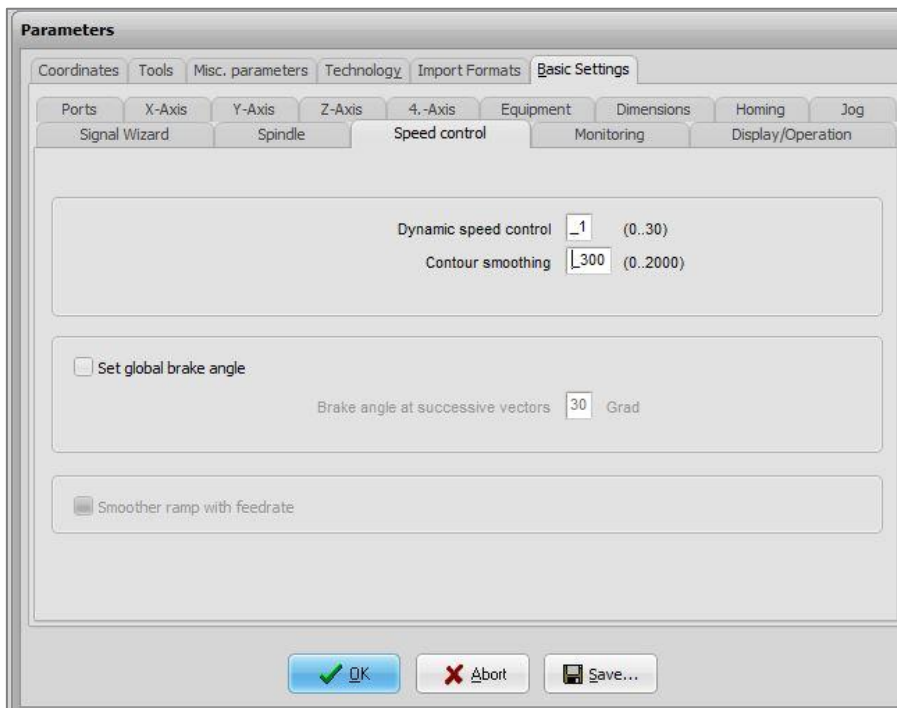

/Basic Settings/Technology/Tangential cutting

All parameters mentioned above need to be set only once. If necessary, the specific tool parameter for the Tangential Knife are to be adjusted in dependence of the material and the feed. The following values are based on experience and tests and represents a good compromise between cutting quality and production time.

- Angle for stopping (deg) = If the change of the angle to the next line exceeds 25 degree, the oscillating blade stops exactly at the cutting point, draws in and proceeds with the job. This prevents unclean cutting lines due to a delayed turning of the blade. The higher the feed, the lower the angle value.
- Angle for lifting (deg) = If the change of the angle to the next line exceeds 40 degree, the oscillating blade stops exactly at the cutting point, retracts from the material, draws in, cuts into the material again and proceeds with the job. This produces a very precise cut that would be impossible to obtain without the retraction of the blade.
- Knife lift = Is the value by which the oscillating blade is raised above the workpiece material for rotation. For an even workpiece surface, a clearance height of 2 mm suffices.

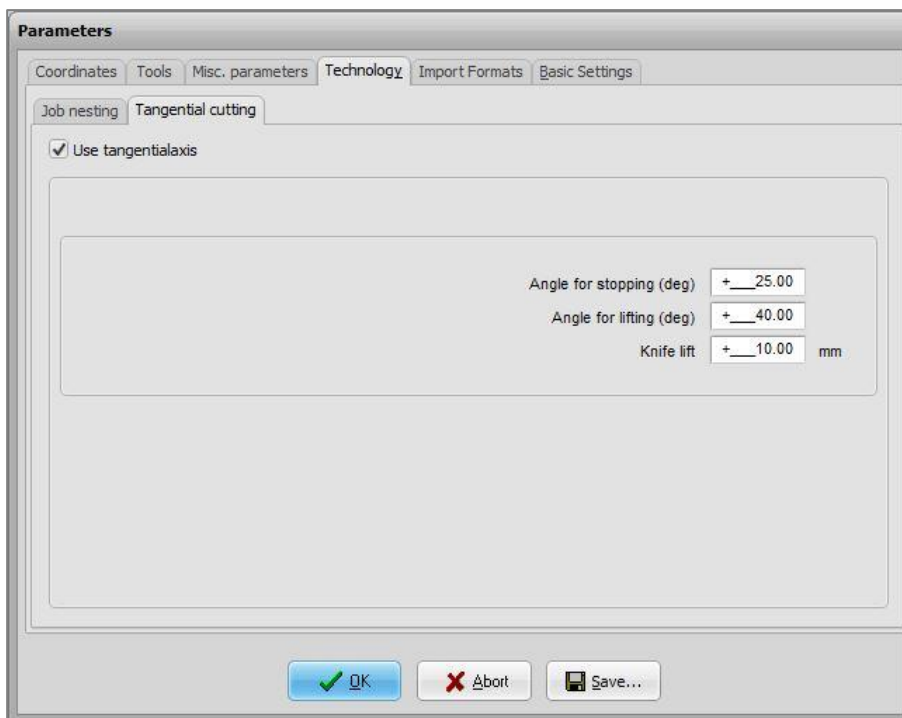

3.2 UCCNC

The successful and safe commissioning of the OTK-3 with UCCNC requires the correct setting of various parameters.

- **Configuration/Axis Setup/A-Axis/**

Die 4th axis has to be activated and all parameters need to be set according to the following screenshot: The motor for the blade positioning requires 3200 steps for a 360° rotation, hence, one degree amounts to 8,889 steps.

Axis enabled

Step pin: 9 port: 1 Active low

Dir pin: 8 port: 1 Active low

Enable pin: 0 port: 0 Active low

Limit - pin: 0 port: 0 Active low

Limit + pin: 0 port: 0 Active low

Home pin: 13 port: 1 Active low Direction positive

Homing speed up (Units/min): 7200

Homing speed down (Units/min): 7200

Write offset on homing (Units): 0 Auto set

Steps per Unit: 8.889

Velocity (Units/min): 21600

Acceleration (Units/s²): 1080

Softlimit - (Units): -100000000

Softlimit + (Units): 100000000

Comp. Acceleration (Units/s²): 1296

Backlash distance (Units): 0 Enable backlash

Slave axis:

- **Configuration/Axis Setup/Spindle/**

PWM spindle

PWM pin: 14 port: 1 Active low

Dir pin: 0 port: 0 Active low

PWM frequency (Hz): 5000

PWM min duty (%): 10 max (%): 100

Spindle velocity (1/min): Min. 10 Max. 100

Spindle relay output enabled

M3 relay pin: 1 port: 1 Active low

M4 relay pin: 0 port: 0 Active low

M3 delay after on (ms): 2000

M3 delay after off (ms): 2000

M4 delay after on (ms): 1000

M4 delay after off (ms): 1000

- **Configuration/General Settings/**

Homing sequence:

1.) Z axis 2.) X axis 3.) Y axis

4.) A axis 5.) None 6.) None

– Offset / G54

Offset Table					
	Current coords	Machine coords	Work offset	G92 offset	Tool offset
X	0.0000	= 0.0000	- 0.0000	- 0.0000	
Y	0.0000	= 0.0000	- 0.0000	- 0.0000	
Z	0.0000	= 0.0000	- 0.0000	- 0.0000	- 0.0000
A	-240.0000	= 0.0000	- 240.0000	- 0.0000	
B	0.0000	= 0.0000	- 0.0000	- 0.0000	
C	0.0000	= 0.0000	- 0.0000	- 0.0000	

Active fixture: G54

Work offset A = Is the value by which the A0 position, the workpiece zero point of the rotation axis, is changed and equals the angle between the switch position of the reference switch as well as the A0 position of the rotation axis of the oscillating blade. The selected CAM software defines the A0 position of the blade's rotation axis. By default, the cutting direction resp. the screw connection (threaded bolt) of the Weldon connection on the A0 position has to point exactly in positive X-direction (see following illustration).

The correction value is approx. 240°.

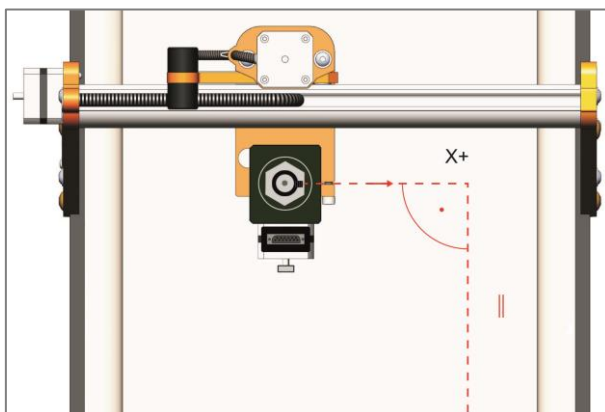

3.3 ENVIRONMENTAL REQUIREMENTS

Make sure that there is sufficient room around the CNC system and the Tangential Knife for them to operate comfortably. The CNC system with the Tangential Knife is to be positioned in an enclosed space.

The Tangential Knife is not to be permanently exhibited to a relative humidity of more than 75 %. Protect the power tool against moisture and humidity.

The environmental temperature of the Tangential Knife should be between 15°C and 25°C.

Especially protect the electronics of the OTK-3 from overheating by avoiding exposure of the control electronics to direct sunlight or close proximity to a heater. Provide adequate lighting for the location of the machine and the Tangential Knife as well as the work place surrounding it.

Position the PC controlling the machine in its near proximity in order to have the CNC system and the Tangential Knife in clear view. All the instructions relevant to the machine and its components must be always kept nearby and within reach.

3.4 EMERGENCY STOP

The emergency-stop switch is located at the front of the STEPCRAFT CNC system.

Pressing the switch triggers an emergency stop of the CNC system and the Tangential Knife. Simultaneously, the power supply to the motors of the OTK-3 is interrupted. In addition, the CNC control software receives a signal to stop the operation. The CNC system will stop immediately.

⚠ CAUTION The emergency stop switch can only lead to a cessation of all components when they are properly connected to the emergency stop functionality of the mainboard.

⚠ WARNING If you are using third-party products, such as another CNC router mainboard, you are solely responsible for connecting the emergency stop functionality properly to the DL445 controller. Otherwise a danger of personal injury or damage to property arises!

If you have any further questions, please do not hesitate to contact us!

3.5 OPTIONAL ACCESSORIES

If you wish to use accessories not manufactured or sold by STEPCRAFT, make sure to check their compatibility with your system prior to its first application.

There are various oscillating blades with different cutting edge lengths available for the OTK-3. All blades are polished solid-carbide knives with a smooth blade suited for different materials, such as cardboard, sealing material, foam rubber, rubber, cork, leather or rigid foam.

Art.-no.	Dimensions	Cutting Depth
11330-001	∅ 6.00 x 36 mm	6 mm
11330-002	∅ 6.00 x 36 mm	10 mm
11330-003	∅ 6.00 x 36 mm	15 mm
11330-004	∅ 6.00 x 46 mm	25 mm
##	∅ 6.00 x ## mm	## mm

4 OPERATION OF THE TANGENTIAL KNIFE

4.1 OPERATOR

The improper operation of the Tangential Knife can cause serious injury and / or property damage.

Read and observe the major accident prevention regulations!

Each user must have read and understood the available instructions for the entire system (CNC router, CNC control, Tangential Knife) before proceeding to operate the device for the first time.

4.2 TANGENTIAL KNIFE

Clamp the Tangential Knife into the 43 mm EURO tool neck of your STEPCRAFT CNC system or into another suitable CNC router. The OTK-3 should be installed with the pointing stroke motor shaft pointing in Y direction in order to prevent a limited work space in the positive X direction.



Connect the controller of the OTK-3 to the system output of your STEP-CRAFT CNC system using the supplied 15-pin D-Sub connection cable. Make sure the blade cannot crush or cut the cable while the machine is moving.

NOTICE: If you have a CNC router from a different brand, check the external documentation to connect the Tangential Knife to the data output of the specific CNC router (see also item 6.2).

The control unit of the Tangential Knife uses the voltage supply of the CNC router mainboard (5 Volts). The positioning motor and the stroke motor operate with a voltage of 30 V. Should the D-Sub interface possess other voltages than 5 and 30 V, please contact the manufacturer.

NOTICE: An additional power supply is not necessary.

NOTICE: Prevent unintentional starting. Ensure the ON/OFF switch is in the OFF position before connecting the Tangential Knife to the main board of the CNC system.

After connecting the control unit, turn the ON/OFF switch of the OTK-3 in the ON-position.

4.3 CNC ROUTER / CONTROL PROGRAM

The Tangential Knife must be controlled by the control software of a CNC router. Therefore, the CNC router must be ready for operation, the CNC control program must be started.

The power and feed of the OTK-3 are only controlled by the CNC control program. A manual control is not possible. The CNC control program must start the oscillation cut. Without an active job signal the Tangential Knife cannot be operated.

4.4 EMERGENCY STOP

The emergency-stop switch is located at the front of the STEP-CRAFT CNC system / the respective CNC router. Additionally, the CNC control software provides software emergency-stop. Pressing either one of the emergency buttons leads to an emergency stop of the machine and the OTK-3. The machine will stop immediately. The OTK-3 will shut off immediately too.

Actuate the emergency-stop switch only in emergency situations.

NOTICE: Actuating the emergency-stop will result in immediate machine shutdown and can cause step and data losses.

Controlled cessation of the machine's operation can only be effected by the control software.

To cancel the emergency stop status, turn the emergency-stop switch to the right. The control is re-enabled. The work process must be restarted.

The entire system is controlled and operated by the PC.

CAUTION

Prior to first usage, read the manual of your control software thoroughly and carefully, making sure that you have understood everything.



For questions regarding the control software, please contact the respective software developer.

4.5 FUNCTION TEST

For this first test run you need to create a test file for the control software of your CNC system. This program moves the oscillating blade within a square (dimensions 50 x 50 mm). It automatically switches the OTK-3 on and off, the blade dives into the material, the Knife moves upwards in the corners, rotates counterclockwise by 90° in the new cutting direction and dives into the material again.

```

/Test program Tangential Knife OTK3
/
G90
G0 X0 Y0
M3 S100          /start oscillation with full speed
G0 A0           /turn of blade in positive X-direction
G0 Z0
G1 Z-5.5 F1000  /cut into the material by 5.5 mm
G1 X50 F600     /move in positive X-direction by 50 mm
G0 Z2          /back out of the material
G0 A90         /blade turn by 90 degrees counter clockwise
G1 Z-5.5 F1000
G1 Y50 F600
G0 Z2
G0 A180        /blade turn by 90 degrees counter clockwise
G1 Z-5.5 F1000
G1 X0 F600
G0 Z2
G0 A270       /blade turn by 90 degrees counter clockwise
G1 Z-5.5 F1000
G1 Y0 F600
G0 Z2
G0 A0         /blade turn by 90 degrees counter clockwise
M5           /stop oscillation
M30
    
```

Prepare the file on your computer using an ASCII editor, e.g. notepad.exe, and save it as “otk-3-test.nc” file. This NC file is also available as download on

<<https://www.stepcraft-systems.com/service/otk-3-test.nc>>.

Perform the first function test **without** a blade.

Procedure:

- Start the CNC control and perform homing.
- Manually drive to the middle of the work space, half Z-height.
- Set the workpiece zero point X, Y and Z. **The zero point for the oscillating blade / Axis A has not to be set due to the work offset.**
- Open the work file and start the program.

The OTK-3 should start automatically, as described above. For the first cut the OTK-3 has to rotate into the positive X-axis, the square is processed counterclockwise.

NOTICE 	Should the Tangential Knife not start as expected and/or should in not rotate in the right cutting direction, check the settings in the control software (chapter 3).
--	--

For a second function test, clamp test material on the CNC machine table, e. g. cardboard, rubber or cork. The workpiece material should at least have a size of 100 x 100 mm. Optimally, the material should be 5 mm thick but every other thickness is also possible as long as the usable blade length is sufficiently long. In this case, the test program has to be adjusted regarding the cutting depth (G1 Z-5.5 F1000) in line 8, 12, 16 and 20.

- Clamp the workpiece material onto the machine table. Ideally, you are working with a vacuum table but you can fix the material as well with double-sided adhesive tape. As the oscillating blade is cutting through the material, you need to place a spoil material under the workpiece material, e. g. a rubber mat (see image on the right).
- Insert the oscillating blade with attached blade protection into the OTK-3. For this purpose, loosen the set screw of the stroke axis and insert the knife carefully into the stroke axis. The Weldon clamping surface points in direction of the set screw. Hold the blade in this position and fix knife by tightening the set screw.
- Move the blade to the lowest point (bottom dead center) by manually turning the hand wheel of the stroke motor.
- Move the tip of the blade carefully above the material. Set the workpiece zero point X / Y at the front left.
- Carefully lower the Z-axis. As soon as the blade tip touches the material, set the workpiece zero point Z.
- **Important: When defining the workpiece zero point, the zero point for the oscillating blade / axis A has not to be set due to the work offset.**
- Start the program, the square is cut out.

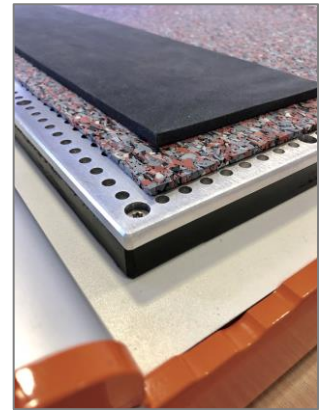

You should obtain a cleanly cut square as result. If necessary, the feed needs to be adjusted in line 9, 13, 17 and 21 (G1 Z-5.5 F600, equals 600 mm/min).

4.6 TESTING THE EMERGENCY STOP FUNCTIONALITY

The testing of the emergency-stop functionality is mandatory.

NOTICE: Do not use the Tangential Knife if the emergency switch of the CNC system is not functioning properly. Any Tangential Knife that cannot be controlled with this switch is dangerous and has to be repaired.

CAUTION 	The Tangential Knife must be controlled by the control software of a CNC router. Prior to each commissioning of the Tangential Knife, the functionality of the emergency switch has to be checked. Malfunction may result in serious personal injury.
---	--

For testing the emergency-stop functionality with the control software of the CNC system, simply start the job in point again. We recommend a repetition check of every emergency switch.

During every operation press one of the emergency buttons. The machine and the operating Tangential Knife must stop immediately.

NOTICE: For questions regarding the control software, please contact the respective software developer.

4.7 CUTTING RECOMMENDATIONS

The maximal cutting depth is dependent on the cutting length, the cutting application, the workpiece material and the available Z-work space. Take into consideration, that the theoretical cutting length resp. workpiece height can maximally amount to the half of the Z-work space minus stroke when the workpiece material needs to be penetrated.

For easily cuttable materials, such as foam sheets, exist no cutting depth limitations due to the stroke power of the OTK-3. Materials that are more difficult to cut, such as rubber, should be cut with a lower stroke rate, if necessary, because the stroke motor of the oscillating blade has a higher torque at a lower speed. Alternatively, the cut can be performed in various passes with increasing infeed depth.

Thermally sensitive materials should be cut with high feed and / or low stroke rate to minimize the development of heat on the blade / the material.

The stroke rate is controlled via the CNC program. The following settings are possible.

General settings for the approximate performance in the NC program:

Performance Setting	Performance Range
S0	No oscillation, grooving operation
S50	1 st stage of performance, approx. 1.300 strokes/minute
S100	2 nd stage of performance (max.), approx. 2.000 strokes/minute

From experience, most materials are cut with maximum stroke number to maximize the feed rate. For a better orientation, the cutting data are listed in the following table:

Material	Material Thickness	Stroke Power	Feed	Number of Passes
Rubber	1 mm	2.000 strokes / min.	8 mm/s	1
Foam rubber	5 mm	2.000 strokes / min.	10 mm/s	1
Foamboard with PS rigid foam core	4,5 mm	2.000 strokes / min.	20 mm/s	1
Leather	1,7 mm	2.000 strokes / min.	8 mm/s	1

NOTICE	The table only represents guiding values; the optimal settings regarding stroke power / feed / number of passes is dependent on the condition of the Tangential Knife resp. the oscillating blade as well as on the composition / quality of the workpiece material.
---------------	--

With many applications, the best results are obtained with an adequate feed at maximum stroke power and, if necessary, various passes. Only a few materials, such as thermally sensitive materials (see above), require a higher feed, a lower power and only one pass. The combination of these three parameters is alterable. A cutting test for the specific application is imperative.

Eventually, testing the settings on an oddment in reference to the table above is the best way to define and adjust stroke power / feed / passes for most materials. By simply observing the process you will soon realize that a lower resp. higher feed in one or two passes with different feeds is more effective.

5 EXEMPLARY CAM-CNC-PROCESS

5.1 CAM WITH VECTRIC VCARVE PRO

The following example shows how a PNG master illustration is processed so that its contours can be cut out with the Tangential Knife.

As example file we use the STEPCRAFT logo which is downloadable from:

<https://stepcraft-systems.com/service/sc-logo-100.png>



We use Vectric VCarve Pro, version 9.512, as CAM program.

Open the program and start a new project. First of all, define the workpiece dimensions as well as the workpiece zero points. The workpiece's width (X) and height (Y) are identical and measure 100 mm each. The workpiece zero point is on the bottom left by default. Enter the thickness (Z) in dependence on the thickness of the material you want to cut. In this example, we will cut foam rubber with a thickness of 5 mm.

Proceed with importing the PNG file:

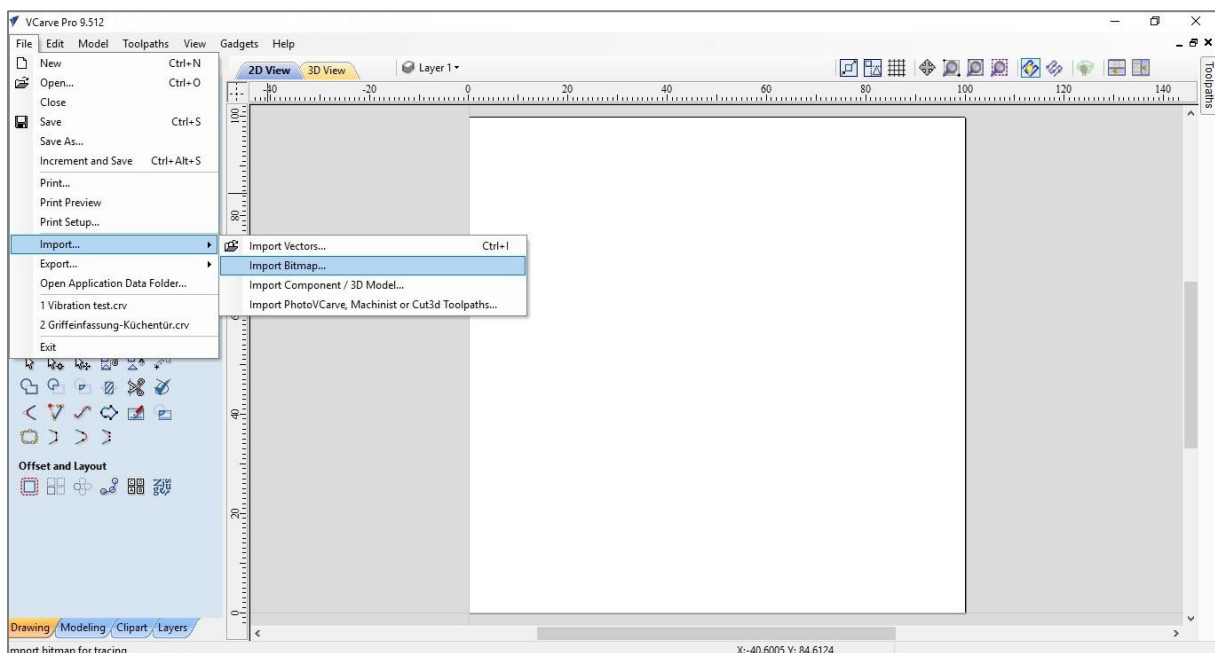
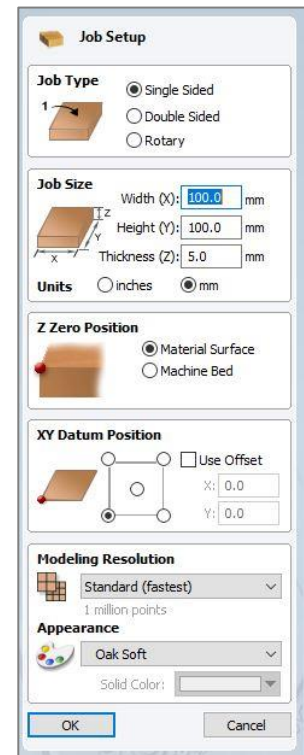

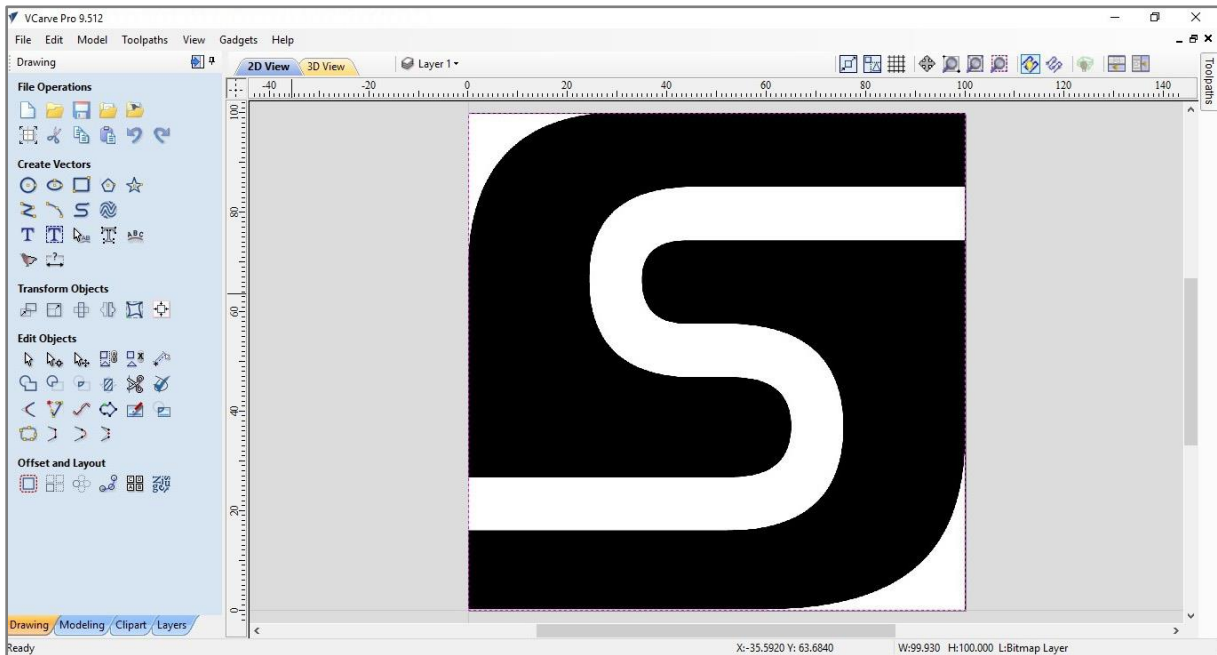

Select the imported logo by clicking the left mouse button, select the scaling tool (left side of the screen) via **Transform Objects / Set Selected Object Size** and enter 80 mm as width / height. Confirm the entry via clicking **Apply**.

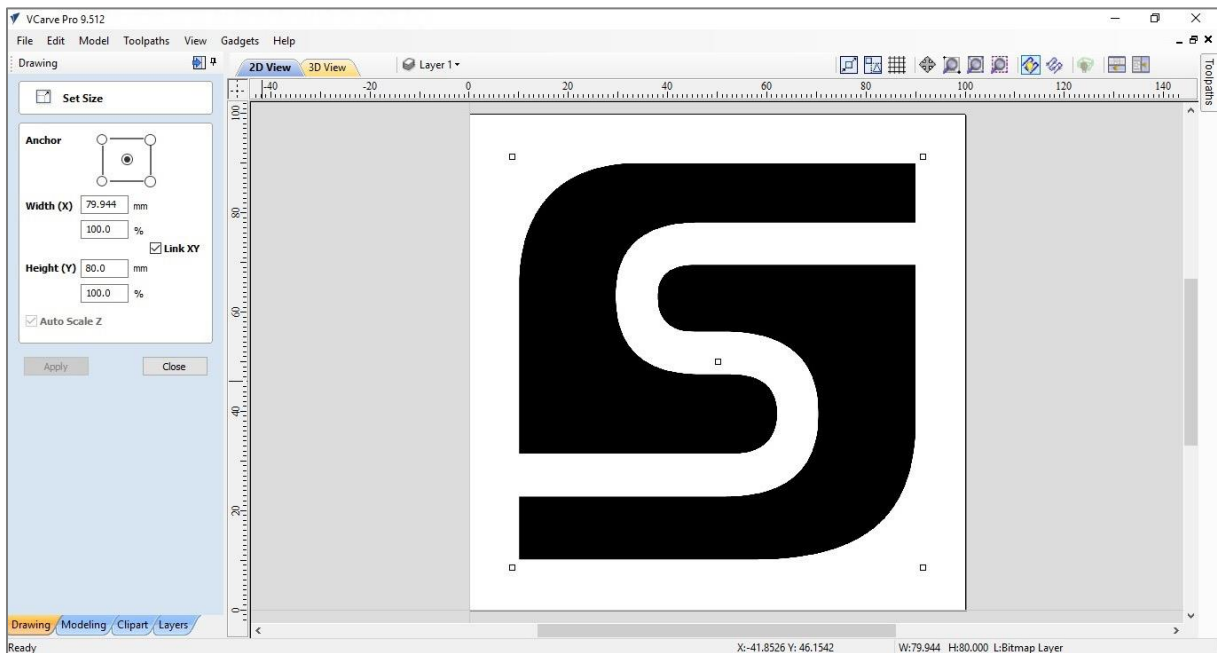

In the next step vectorize the logo resp. the contour, meaning the transformation in clearly defined curves and lines. For this purpose, select the logo again by clicking the left mouse button. Select the tool **Create Vectors / Trace Bitmap** on the left side of the screen.

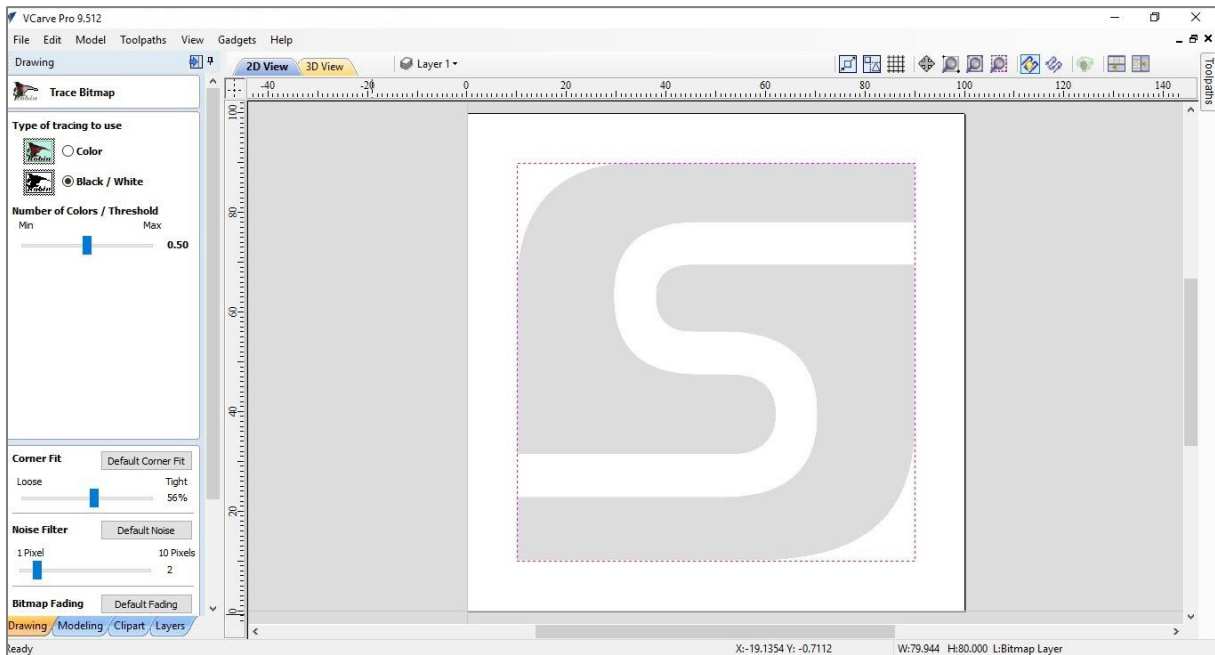

As type of tracing select black / white. Leave all other settings, e. g. corner fit and noise filter, at the default values. View the result of the vectorization via the preview button. By clicking **Apply** the illustration is converted into vectors.

Afterwards, the vectors need to be converted into curves. For this purpose, Vectric offers the tool **Edit objects / Curve Fit** on the left side of the screen. Select the logo again and open the tool.

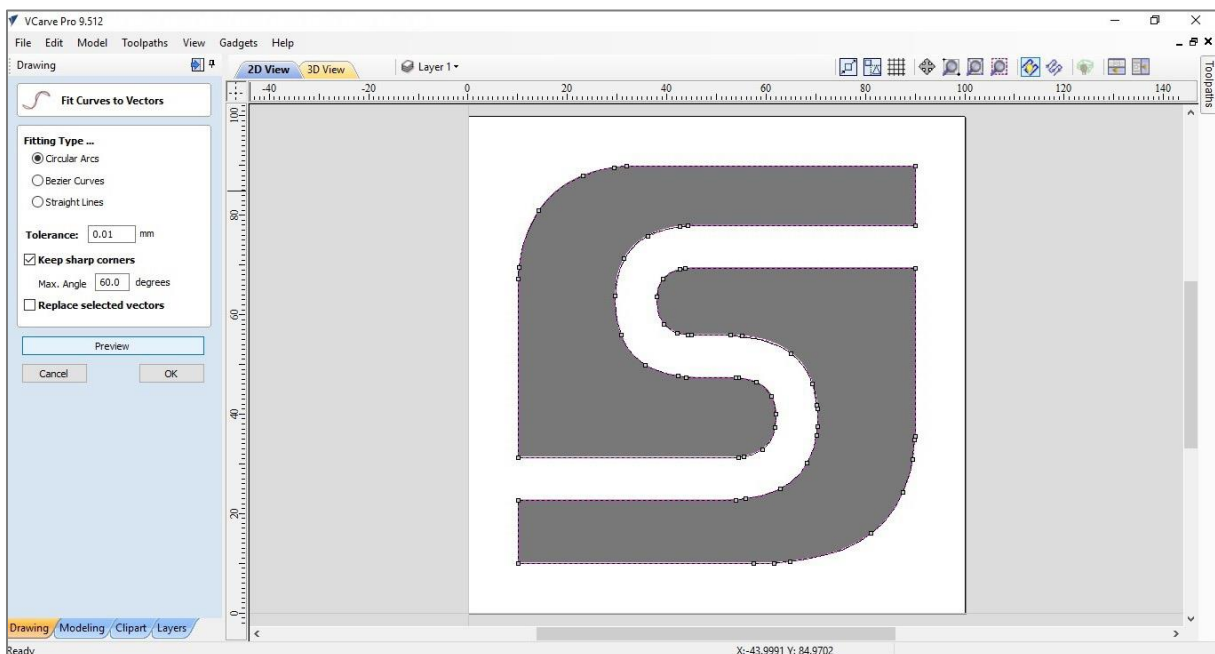

With the default settings, circular arc with a 0,01 mm tolerance, you will receive a good result. The parameters can also be set differently. Via the preview function you can directly see the adjusted settings.

Press **Ok**. In the main view, select the black filling of the logo by clicking the left mouse button. Delete the filling by activating the **DEL button** on your keyboard. You only need the contour for the Tangential Knife.

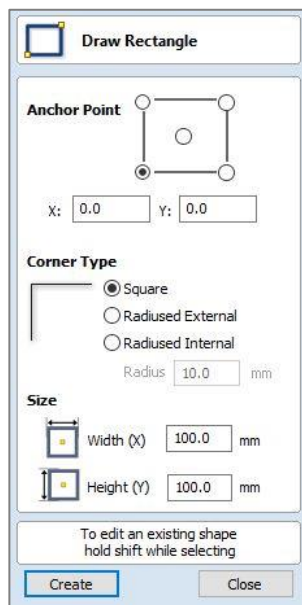
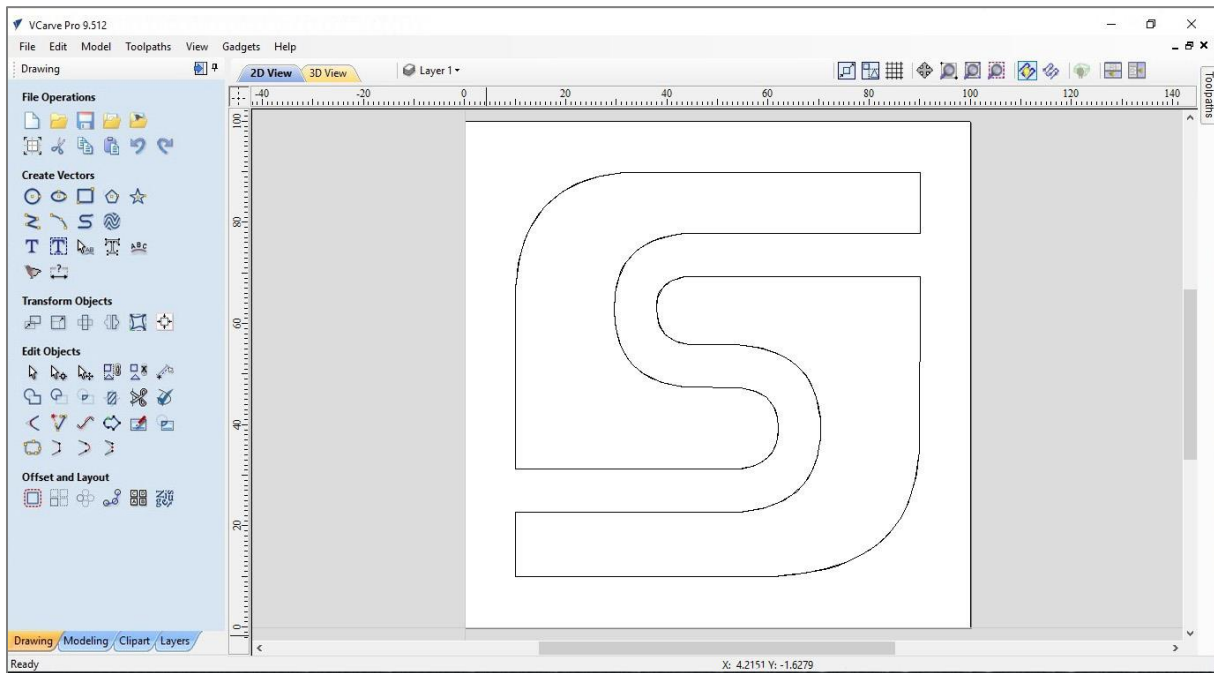

To draw the outer contour of the square, open the tool **Create Vectors / Draw Rectangle**. As the anchor point is at the bottom left (workpiece zero point), the value for X and Y has to be 0. The width (X) and height (Y) are identical with each 100 mm.

By clicking **Create**, the menu closes and the square is drawn in. As with the two logo elements, you can select it with the left mouse button.

Finally, the vector graphics are exported as DXF file. You can save the file via **File / Export /DXF**.

<<https://stepcraft-systems.com/service/sc-logo-100.dxf>>

5.2 CNC WITH WINPC-NC

Start WinPC-NC, initialize the machine and open the DXF file **sc-logo-100.dxf**.

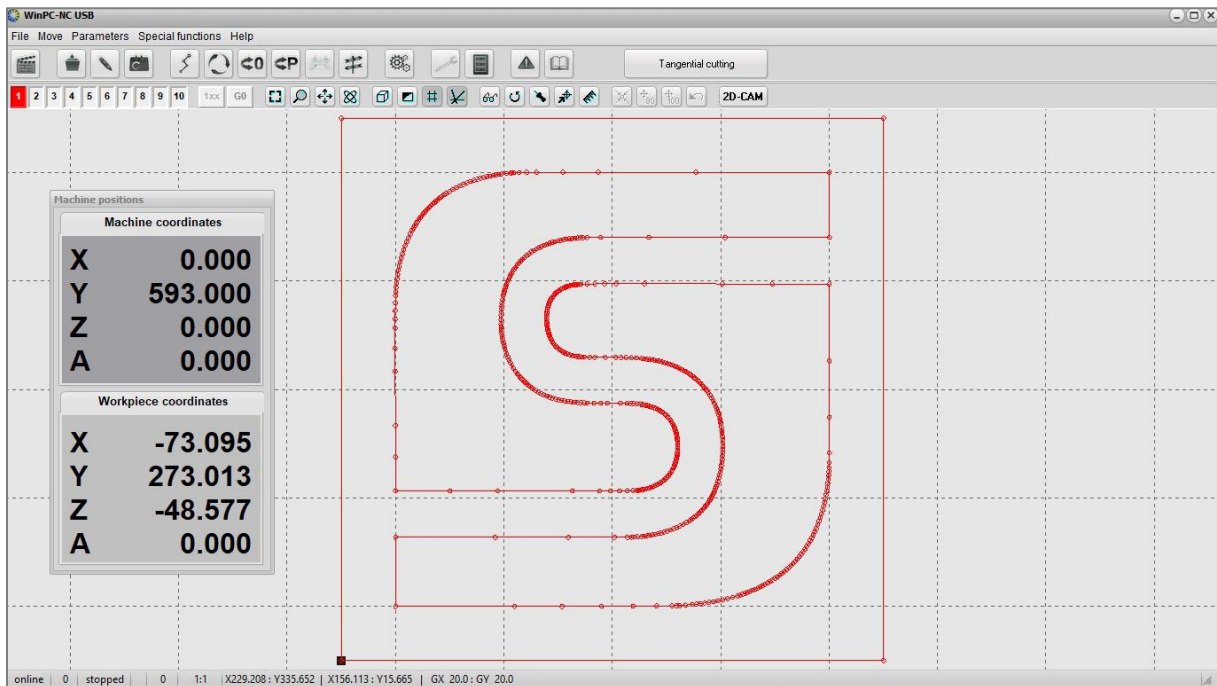

On closer inspection of the circular arcs, you will see that the circular arcs are created out of a multitude of single aligned arcs.

This conversion error can be automatically corrected in WinPC-NC with the 2D-CAM functionality. Open the tool by clicking on the button **2D-CAM** at the top of the screen.

Select the following positions in the tab Actions:

- Clean up original data
- Join lines and contours with a catching grid of 0,1 mm
- Nesting contours
- Tool diameter compensation and include original data to new file
- Minimize empty moves

By clicking **Start** the calculation starts. The changes made are listed in the tab Results. Close the window by clicking **Done**. After the cleaning of the vector file, WinPC-NC will show a continuous contour drawn with a line.

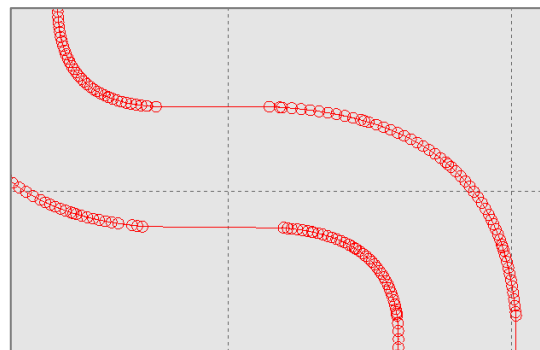

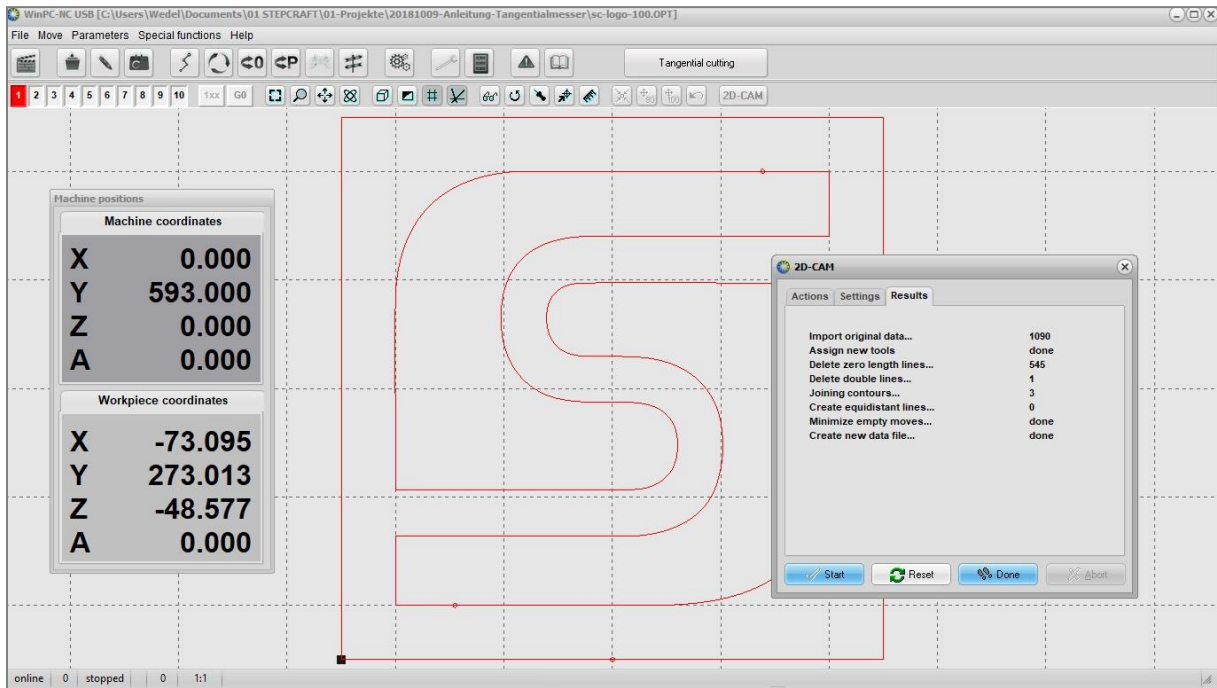

Finally, after all other settings were defined in point 3.1, the tool parameters for the Tangential Knife need to be set.

Under Parameters / Tools / Activation Werkzeug 1 (red color, see logo color) has to be activated. The value for the spindle speed is 100. This equals 100 % of the maximum speed of 2000 strokes / minute.

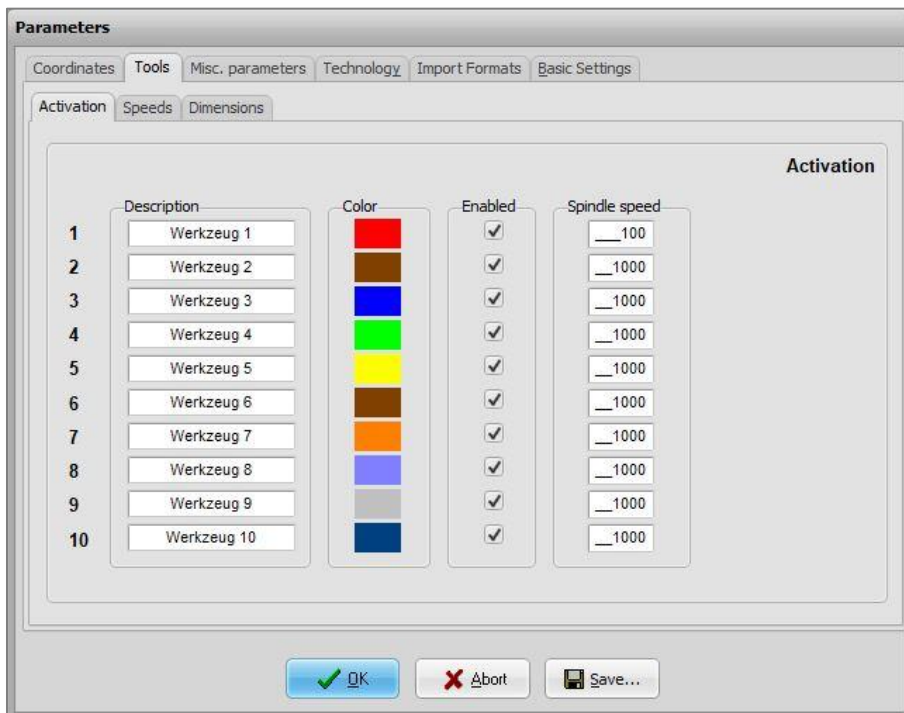

Enter the speeds for plunge (5 mm/s), advance (10 mm/s) and withdrawal (5 mm/s) of the oscillating blade under / **Parameters / Tools / Speeds**.

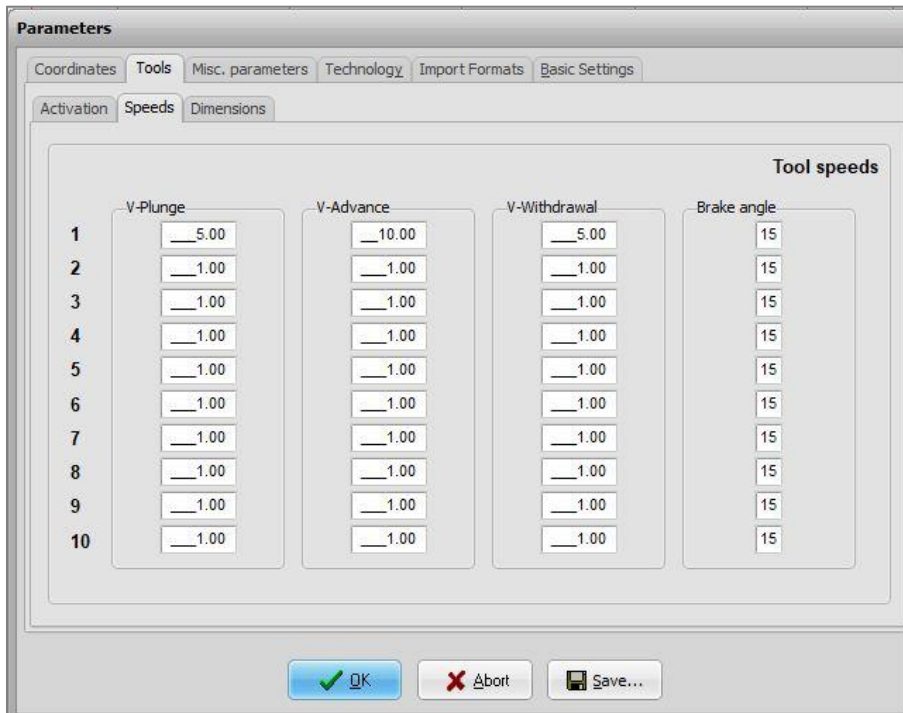

- Define the depth of the first cut under / **Parameters / Tools / Dimensions**. As the material to be cut has a thickness of 5,0 mm, select a feed value of 5,5 mm to make sure the material is completely cut through.
- Zero the values for the number of additional cuts as well as the additional cut depth.

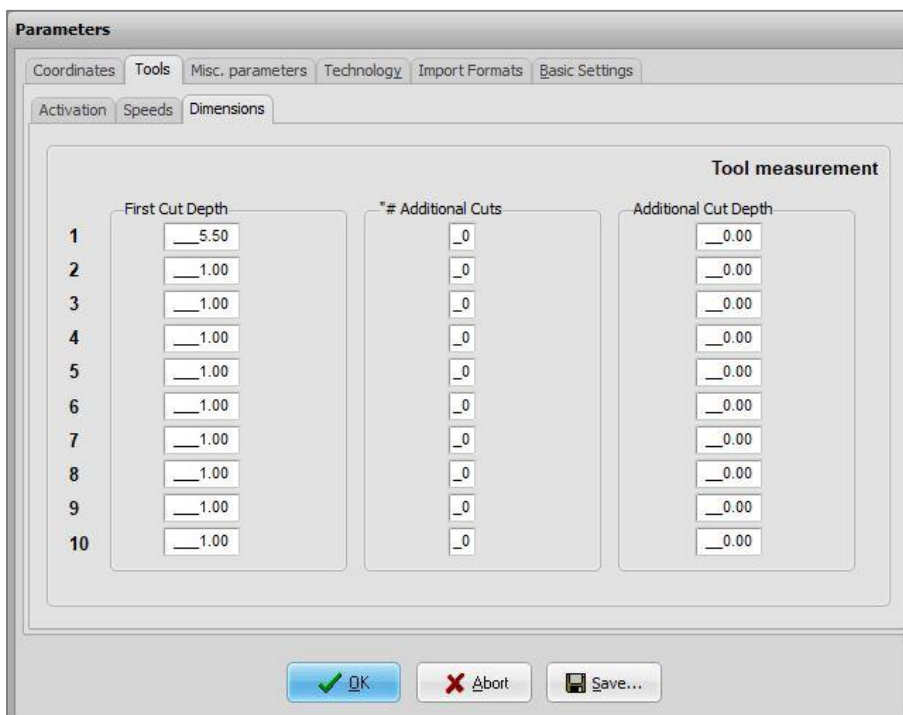

Secure the material to be cut, as shown by example in point **Fehler! Verweisquelle konnte nicht gefunden werden.**, and set your workpiece zero point for X, Y and Z.

Afterwards, start the CNC program.

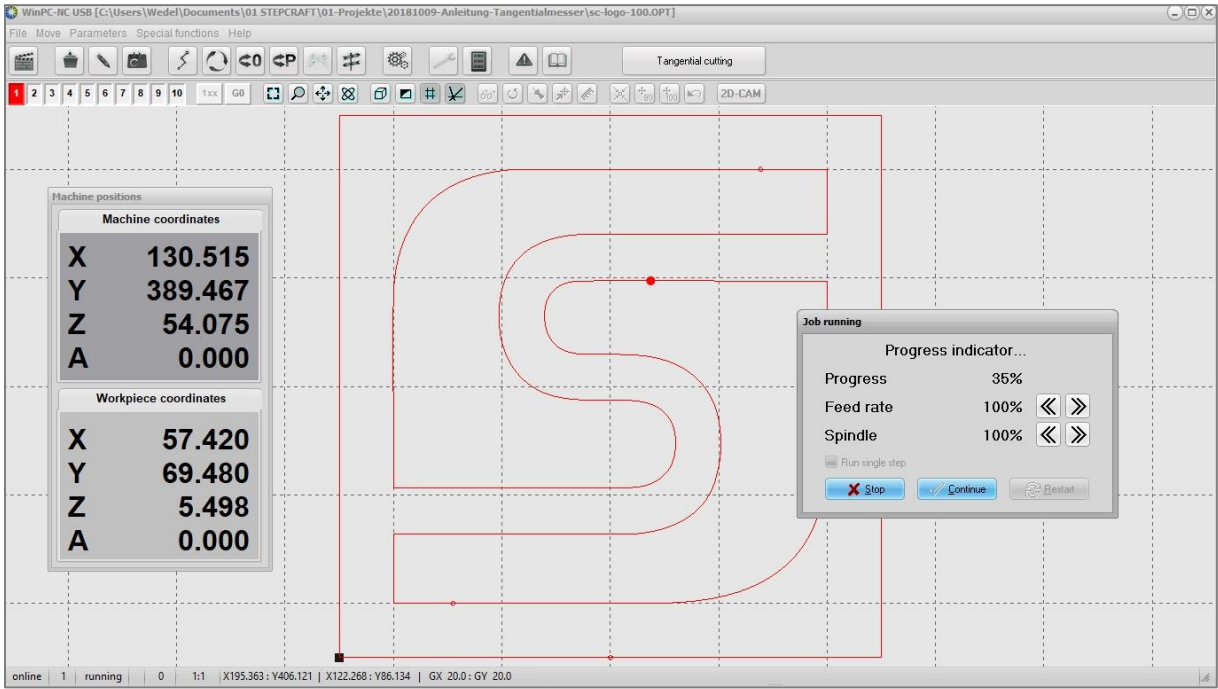

6 TECHNICAL SPECIFICATIONS

6.1 POWER, DIMENSIONS AND WEIGHT OF THE TANGENTIAL KNIFE

- Product name: OTK-3
- Stroke power knife: 90 N with maximum stroke number
- Maximum stroke number: 2000 strokes / minute
- Oscillation mode: Grooving operation / 1300 strokes / 2000 strokes
- Stroke: 3,0 mm
- Shaft diameter tool: 6,0 mm
- Tool interface: Weldon shaft
- Dimensions (L x W x H): 98 x 52 x 160 mm
- Clamping neck: 43 mm (EURO neck)
- Weight: 1,08 kg (without oscillation blade, connection cable)
- Casing: Aluminum 7075 anodized
- Voltage motors: 30 V
- Voltage control electronics: 5 V

6.2 PIN ASSIGNMENT OF THE INTERFACE (15-PIN D-SUB INPUT SIGNALS)

Pin no.	Function	Pin no.	Function
1	+ 30 Volt	9	+ 30 Volt
2	GND	10	GND
3	+ 5 Volt	11	Emergency stop switch
4	Direction 4 th axis (blade position)	12	Reference switch 4 th axis
5	Pulses 4 th axis	13	Holding current on/off (0 = idle mode, 1 = Job runs)
6	Oscillation mode (PVM, 0 V = grooving operation, 1 V = 1300 strokes / minute, 3 V = 2000 strokes / minute)	14	free
7	free	15	free
8	free		

7 TRANSPORT / STORAGE

7.1 TRANSPORT

Please make sure that the Tangential Knife is not exposed to heavy shocks during transport. This can lead to unwanted damages. If necessary, transport the device in suitable containers.

⚠ WARNING Entfernen Sie die Klinge aus dem Tangentialmesser vor dem Transport. Beim Handling des Werkzeugs kann es ansonsten schnell zu ernsthaften Schnittverletzungen kommen.

7.2 PACKAGING

If you do not want to re-use the packaging material of the Tangential Knife, remove it properly and according to disposal conditions at the site and carry it to the recycling or disposal unit.

7.3 STORAGE

In case of prolonged downtime of the Tangential Knife, please observe the following storage conditions:

- Store the device and its components in an indoor environment.
- Protect from moisture, humidity, cold, heat and direct sunlight
- Store in a dust-free environment, cover if necessary
- The storage site should be free of any vibrations.

8 MAINTENANCE INFORMATION

8.1 SERVICE

To ensure continued enjoyment of your STEPCRAFT OTK-3, handle it carefully.

Regular maintenance positively affects the life expectancy of the device.

⚠ WARNING	Preventive maintenance performed by unauthorized personnel may result in misplacing of internal wires and components which could cause serious hazard. We recommend that all tool service be performed by a STEPCRAFT service facility.
------------------	--

⚠ WARNING	To avoid injury from unexpected starting, turn the switch of the Tangential Knife into the "OFF" position and always remove D-sub cable from the Tangential Knife before performing any service or maintenance works.
	

8.2 CLEANING

The cut with the Tangential Knife generates no dust contaminating the tool. The occasional cleaning with a soft cloth is totally sufficient.

NOTICE	A cleaning with compressed air is not recommended.
---------------	---

⚠ CAUTION	Certain cleaning agents and solvents damage plastic parts and/or the coating. Some of these are: gasoline, carbon tetrachloride, chlorinated cleaning solvents, ammonia and household detergents that contain ammonia.
------------------	---

8.3 LUBRICATION

The lubrication of the stroke axis slot and the actuating cam needs to be checked after every 50 operating hours:

- Loosen the screw of the maintenance cover (Allen wrench 2,0 mm) and remove the cover.
- Check the lubrication.
- If necessary, apply a bit maintenance grease, type KLÜBER ISOFLEX NBU 15, with a small brush or a cotton bud onto the upper and lower running surface of the slot. Turn the rotating axis for an even lubrication of the running surfaces.
- Put the maintenance cover back into the casing and tighten it with a screw.

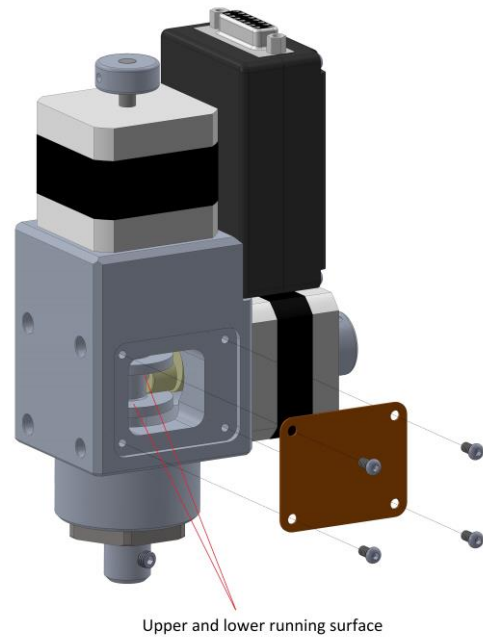

⚠ VORSICHT The continued used of the tool in unmaintained condition will permanently damage your tool.

9 FAILURE

9.1 RESPONSE TO MALFUNCTIONS

⚠ VORSICHT If a failure occurs on the device that could cause personal injury or property damage, stop the operation immediately using the emergency switch!

NOTICE: For less serious malfunctions, stop the machine / device normally using the controller. If you cannot fix the malfunction yourself, please contact us, specifying the fault, which has occurred.

Our contact details can be found on the front page of this manual.

10 APPENDIX

10.1 WARRANTY AND SERVICE CONTACT INFORMATION

Country of Purchase	STPCRAFT	Address	Phone no. / E-mail address
United States of America	STPCRAFT Inc.	59 Field Street, Rear Building, Torrington, CT, 06790	+1 203 556 1856 info@stepcraft.us
Germany	STPCRAFT GmbH & Co. KG	An der Beile 2 58708 Menden Germany	+49 2373 179 11 60 info@stepcraft-systems.com
Rest of the world	Local distributor	see https://www.stepcraft-systems.com/en/retail	see https://www.stepcraft-systems.com/en/retail
	STPCRAFT GmbH & Co. KG	An der Beile 2 58708 Menden Germany	+49 2373 179 11 60 info@stepcraft-systems.com

10.2 MANUFACTURER

STPCRAFT GmbH & Co. KG
An der Beile 2
58708 Menden
Germany

Phone: +49 (0) 2373 – 179 11 60
E-mail: info@stepcraft-systems.com
Website: www.stepcraft-systems.com

10.3 IDENTIFICATION PLATE

The type plate can be found at the rear of the maintenance cover of the Tangential Knife:



10.4 COPYRIGHT

The contents of these operating instructions are the intellectual property of the STEPCRAFT GmbH & Co. KG. Forwarding or copying (also in excerpts) is not allowed without our explicit a written authorization. Any infringements are prosecuted.

10.5 LIMITED WARRANTY

What this warranty covers

STPCRAFT GmbH & Co. KG (“STPCRAFT”) warrants to the original purchaser that the product purchased (the “product”) will be free from defects in materials and workmanship at the date of purchase.

What is not being covered

This warranty is not transferable and does not cover (i) cosmetic damage, (ii) damage due to acts of God, accident, misuse, abuse, negligence, commercial or improper use, installation, operation or maintenance, (iii) modification of or to any part of the product, (iv) attempted service by anyone other than a STEPCRAFT authorized service center, (v) products not purchased from an authorized STEPCRAFT dealer, or (vi) products not compliant with applicable technical regulations.

OTHER THAN THE EXPRESS WARRANTY ABOVE, STEPCRAFT MAKES NO OTHER WARRANTY OR REPRESENTATION AND HEREBY DISCLAIMS ANY IMPLIED WARRANTIES, INCLUDING, WITHOUT LIMITATION, THE IMPLIED WARRANTIES OF NON-INFRINGEMENT, MERCHANTABILITY AND FITNESS FOR A PARTICULAR PURPOSE. THE PURCHASER ACKNOWLEDGES THAT HE ALONE HAS DETERMINED THAT THE PRODUCT WILL SUITABLY MEET THE USE.

Purchaser's remedy

STEPCRAFT's sole obligation and purchaser's sole and exclusive remedy shall be that STEPCRAFT will, at its option, either (i) service, or (ii) replace any product determined by STEPCRAFT to be defective. STEPCRAFT reserves the right to inspect any and all product(s) involved in a warranty claim.

SERVICE OR REPLACEMENT AS PROVIDED UNDER THIS WARRANTY IS THE PURCHASER'S SOLE AND EXCLUSIVE REMEDY.

Limitation of liability

STEPCRAFT SHALL NOT BE LIABLE FOR SPECIAL, INCIDENTAL OR CONSEQUENTIAL DAMAGES, LOSS OF PROFITS OR PRODUCTION OR COMMERCIAL LOSS IN ANY WAY, REGARDLESS OF WHETHER SUCH CLAIM IS BASED IN CONTRACT, WARRANTY, TORT, NEGLIGENCE, STRICT LIABILITY OR ANY OTHER THEORY OF LIABILITY, EVEN IF STEPCRAFT HAS BEEN ADVISED OF THE POSSIBILITY OF SUCH DAMAGES. Further, in no event shall the liability of STEPCRAFT exceed the individual price of the product on which liability is asserted. As STEPCRAFT has no control over usage, setup, final assembly, modification or misuse, no liability shall be assumed or accepted for any resulting damage or injury. By the act of use, setup or assembly, the user accepts all resulting liability. If you as the purchaser or user are not prepared to accept the liability associated with the use of the product, the purchaser is advised to return the product immediately in new and unused condition to the place of purchase.

Law

These terms are governed by German law (without regard to conflict of law principals).

This warranty gives you specific legal rights additional to other rights you may have. STEPCRAFT reserves the right to change or modify this warranty at any time without notice.

Warranty services

Questions, assistance, and service

Your local STEPCRAFT store and / or place of purchase cannot provide warranty support or service. Once assembly, setup or usage of the products has been started, you must contact your local distributor or STEPCRAFT directly. This will enable STEPCRAFT to better answer your question and help you in the event that you may need any assistance. For questions or assistance, please visit our website or call us in order to speak to a product support representative (see contact details **Fehler! Verweisquelle konnte nicht gefunden werden.**).

Inspection or services

If this product needs to be inspected or serviced and is compliant in the country you live and use the product, please use the STEPCRAFT online service request submission process found on our website or call STEPCRAFT. Pack the product securely using a shipping carton. Please note that original boxes may be included but are not designed to withstand the rigors of shipping without additional protection. Ship via a carrier that provides tracking and insurance for lost or damaged parcels, as

STEEPCRAFT is not responsible for merchandise unit it arrives and is accepted at our facility. When calling STEPCRAFT, you will be asked to provide your complete name, street address, email address and phone number where you can be reached during business hours. When sending products to STEPCRAFT, please include your contact details and a list of the items included as well as a brief summary of the problem. A copy of your original sales receipt must be included for warranty consideration. Be sure your name and address are clearly written on the outside of the shipping carton.

Warranty requirements

For warranty consideration, you must include your original sales receipt verifying the proof-of-purchase date. Provide warranty conditions have been met, your product will be serviced or replaced free of charge. Service or replacement decisions are at the sole discretion of STEPCRAFT.

NON-warranty service

Should your service not be covered by warranty, service will be completed and payment will be required without notification or estimate of the expense unless the expense exceeds 50% of the retail purchase cost. By submitting the item for service, you are agreeing to payment of the service without notification. Service estimates are available upon request. You must include this request with your items submitted for service. Non-warranty service estimates will be billed a minimum of ½ hour of labor. In addition, you will be billed for return freight. STEPCRAFT accepts money orders cashier’s checks as well as credit cards and PayPal payment. By submitting any item to STEPCRAFT for service, you are agreeing to STEPCRAFT’s Terms and Conditions found on our website (see contact details on front page).

ATTENTION: STEPCRAFT service is limited to product compliant in the country of use and ownership. If received, a non-compliant product will not be serviced. Further, the sender will be responsible for arranging return shipment of the unserviced product through a carrier of the sender’s choice and at the sender’s expense. STEPCRAFT will hold non-compliant product for a period of 60 days from notification after which it will be discarded.

10.6 DISPOSAL

Instructions for the disposal of WEEE by users of the European Union:

	<p>This product must not be disposed of with other waste. Instead, it’s the user’s responsibility to dispose of their waste equipment by handing it over to a designated collection point for the recycling of waste of electrical and electronic equipment. The separate collection and recycling of your waste equipment at the time of disposal will help to conserve natural resources and ensures that it is recycled in a manner that protects human health and the environment. For more information about where you can drop off your waste equipment for recycling, please contact your local office, your house-hold waste disposal or where you purchased your product.</p>
---	--

10.7 RoHS, 2002/95/EG

We confirm that the STEPCRAFT OTK-3 complies with the RoHS, 2002/95/EC.

10.8 EC-DECLARATION OF CONFORMITY



EC Manufacturer's Declaration of Conformity

in terms of the directive 2006/42/EC, appendix II

Manufacturer: STEPCRAFT GmbH & Co. KG
Address: An der Beile 2, 58708 Menden, Deutschland
Type of product: Oscillating Tangential Knife
Type designation: OTK-3

Hereby we declare that the device named above is consistent with the following relevant regulations:

- **EU machine directive 2006/42/EC**
- **EC EMC directive 2004/108/EC**

Applied harmonized standards, whose references have been published in the Official Journal of the European Communities:

EN 61029-1 Safety of transportable motor-operated electric tools,
Part 1: General requirements

Representative for the compilation of the technical documentation is the signatory of this declaration.

This declaration becomes void if not authorized modifications are made to the device.

Menden, 30th of November 2018

STEPCRAFT GmbH & Co. KG,
An der Beile 2, 58708 Menden

Markus Wedel
Commercial Director

**Copyright ©
STEEPCRAFT™**