

GHBH Series

GHBH 004 34 2R5

Technical datasheet



Goorui blower performance curves

Vacuum selection diagram curve

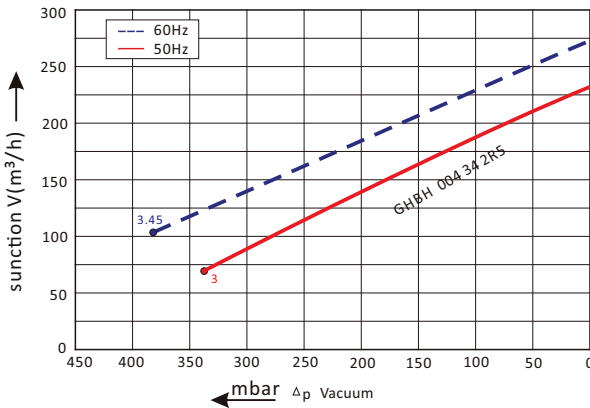

Compressor selection diagram curve

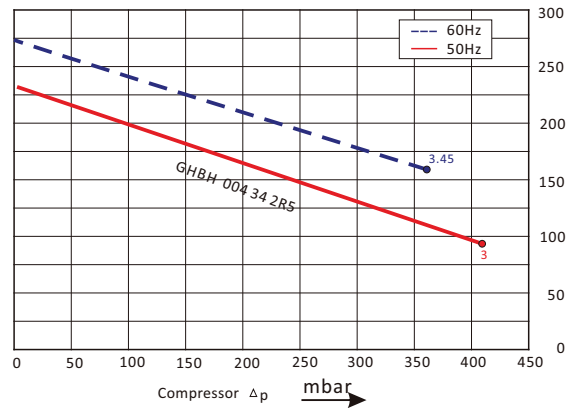

Goorui blower installation drawing

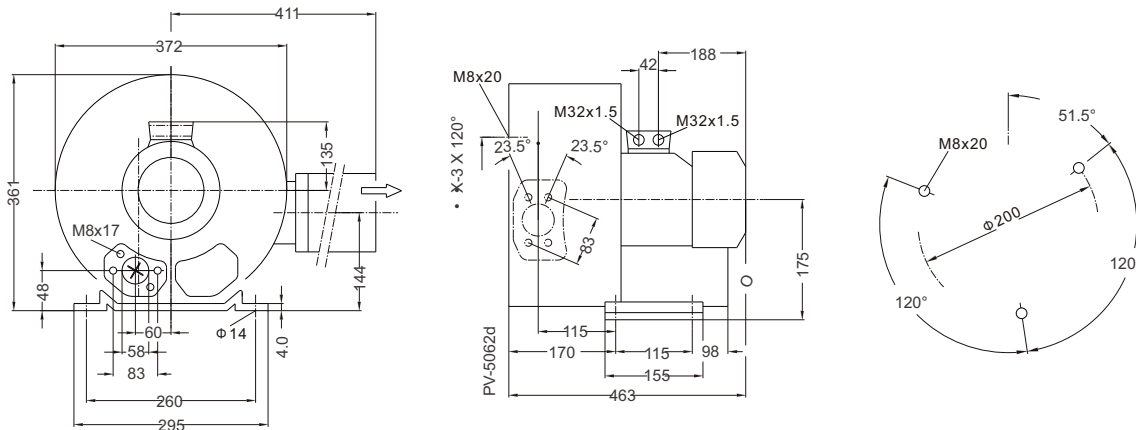

Goorui blower parameter

Model	Frequency	Output	voltage	Current	airflow	pressure		noise	Weight
	Hz	KW	V		m³/h	vacuum mbar	compressor mbar	dB(A)	
3~ 50/60Hz IP54 INSULATION class F									
GHBH 004 34 2R5	50	3	200-240 Δ /345-415Y	12.5 Δ /7.2Y	230	-340	410	72	39
GHBH 004 34 2R5	60	3.45	220-275 Δ /380-480Y	12.5 Δ /7.3Y	275	-380	360	74	39

The performance curves of Goorui blower is tested through below ways:

Under one atmospheric pressure, suck 15°C air and then you can calculate the data, of course allow 10% difference, and when the sucked air and surroundings temperature are not higher than 25°C, you still can get total pressure difference as the curves shows.