



Description

The WLS 1 consists of a base body made of high-quality aluminum, precisely turned and milled, a wear-resistant probe head made of stainless steel and a built-in microswitch.

It has a switching path of about 2 mm, then the probe head can be pressed together a further 4 mm in order to prevent destruction of the tool to be measured (safety path, e.g. necessary if the ramp is too large). It is provided with a three-wire cable and can be connected as a normally closed or normally open contact. Two M4 Allen screws are provided for fastening.

Application

The sensor is used on CNC machines to determine the tool length in the Z direction.

Connection

As a normally closed contact (NC):
between the core colors brown (BN) and white (WH).

As a normally open contact:
Between the core colors brown (BN) and gray (GY).



Technical specifications

Electric	
Voltage max.	250 V
Current max.	5 A

Dimensions	
Diameter	34 mm
Height	approx. 34 mm
Probe head diameter	8 mm
Release path	approx. 2 mm
Total way	approx. 6 mm
Repeatability	±0,01 mm
Cable length	3 m

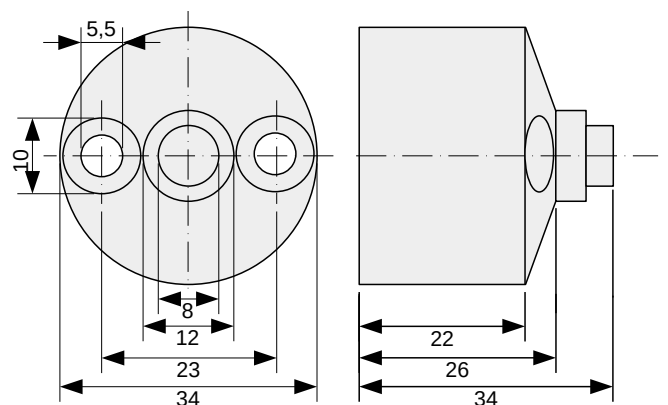

Materials	
Body	Aluminium 6061
Probe head	1.4305; X8CrNiS18-9
Cable	PVC, 3 x 0,14 mm ²