

# iHSS(C)86

# Integrated Stepper Motors CL

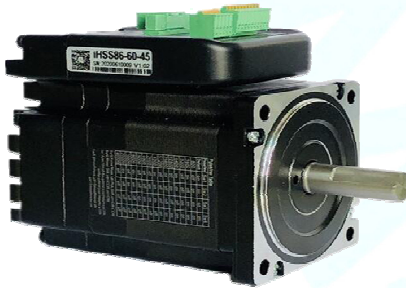

## 1. Features

- Cost-effective closed loop stepper motor solution
- High positioning accuracy
- No stepp losses
- Smooth and reliable moving at low speed
- Compact size
- Pulse Input Mode Pulse + Direction
- Variable current control technology, thus high current efficiency
- Parameters to download via RS232 to PC.
- Users can define subdivisions via external Dial-up switches or via software.
- Over-current, over-voltage and position-deviation protections.

## 2. Description:

The iHSSXX merged stepper driver and motor together. This motor system integrates the servo control technology into the digital stepper drive perfectly. Further, this product adopts an optical encoder with high speed position sampling feedback of 50µs, once the position deviation appears, it will be fixed immediately. This product is combines the advantages of the stepper drive and servo drive, such as lower heat, less vibration, fast acceleration, and so on.

## 3. Applications:

iHSSXX can be used in various applications such as laser cutters, laser markers, high precision X-Y tables, labelling machines, CNC router, etc. Its unique features make the iHSSXX an ideal choice for applications that require low-speed smoothness by small mounting space.

## 4. Naming Rules:

**IHSSXX-XX-XXX-XX-XX-XX-YY**

1 2 3 4 5 6 7 8

1. Integrated Closed Loop Stepper motor (iHSSC ≙ Integrated Closed Loop Stepper Motor with Polarity-Protection)
2. Motor frame size: 86 ≙ 86 mm
3. Motor rated DC voltage: 60 ≙ 60 V / 80 ≙ 80 V
4. Holding torque: 45 ≙ 4.5 Nm / 100 ≙ 9.6 Nm
5. Shaft length: no digit ≙ 38 mm
6. Pilot diameter: no digit ≙ 73 mm
7. Square hole distance: no digit ≙ 69.58 mm
8. Special equipment: SC ≙ with brake  
RC ≙ MOD-/CAN-Bus  
POCA ≙ It is necessary to disconnect the power supply to reset an alarm

## 5. Electrical Specification:

Parameters:	Min	Typical	Max	Unit
Input Voltage	24	60 (80 *)	80 (100 *)	VDC
Output current		6		A
Pulse per revolution	4	-	51,200	-
Pulse input frequency		-	200	kHz
Pulse Voltage	-	5	24	V
Logic Signal Current	5	10	20	mA
Isolation Resistance	100 / 500	-	-	MΩ / V DC
Insulation class		B		

\*) iHSS(C)86-80-100; iHSS(C)86-80-120

# iHSS(C)86

# Integrated Stepper Motors CL

## 6. Motor Specification:

Part Name:	iHSS(C)86-60-45	iHSS(C)86-80-100	iHSS(C)86-80-120			Unit
Current / phase	6.0	6.0	6,0			A
Number of phases	2	2	2			-
Holding Torque	4.5	9.8	12.2			Nm
Inductance / phase	4.0	3.7	8,4			mH ± 20%
Resistance / phase	0.29	0.57	0,76			Ω ± 10 %
Inertia	1,400	3,100	4.000			g*cm <sup>2</sup>
Weight	2.8	4.8	5,9			kg

## 7. Operating Environment:

Cooling	Natural cooling or forced air cooling	
Operating Environment	Environment	Avoid dust, oil, fog and corrosive gases
	Ambient Temperature	0 °C - 40 °C
	Humidity	40 % RH to 90 % RH
	Operating temperature (motor case)	max. 90 °C
Storage Temperature	-20 °C to 65 °C	

## 8. Mechanical Specifications:

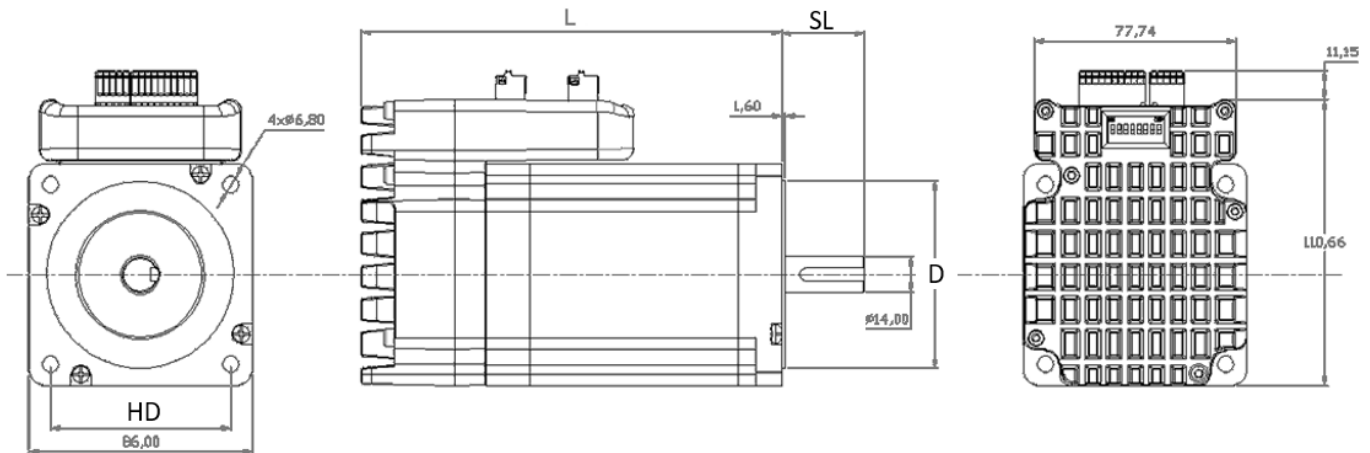

Name	Length of motor and drive L	Shaft length SL	Pilot diameter D	Square hole distance DH
iHSS(C)86-60-45	121 ± 1 mm	38 ± 1 mm	73 mm	69,58 mm
iHSS(C)86-80-100	173.5 ± 1 mm	38 ± 1 mm	73 mm	69,58 mm
iHSS(C)86-80-120	202 ± 1mm	38 ± 1 mm	73 mm	69,58 mm

# iHSS(C)86

# Integrated Stepper Motors CL

## 9. Protection Indications:

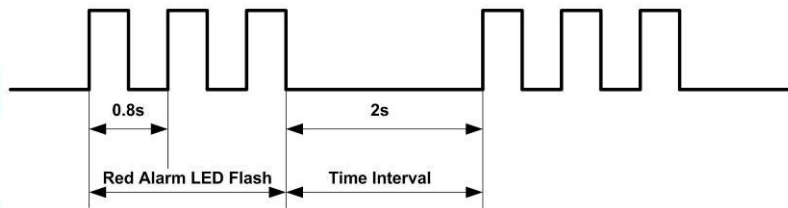

LED light flashes	Alarm description
1 time	Error occurs when the motor coil current exceeds the drive's current limit.
2 times	Voltage reference error in the drive
3 times	Parameters upload error in the drive
4 times	Error occurs when the input voltage exceeds the drive's voltage limit.
5 times	Error occurs when the actual position following error exceeds the limit.

## 10. Connectors and Pin Assignment

The iHSSXX have three connectors, one connector for power connections, another one for control signal connections and a third one for RS232 communication connections.

Power Connector +VDC			
Pin	Name	I/O	Description
1	DC+	I	Power Supply Input (Positive) 24 – 60 (80 *) VDC is typical. Recommended to leave reasonable reserve for voltage fluctuation and back-EMF during deceleration. *)iHSS86-80-100
2	GND	GND	Power Ground (Negative)

Control Signal Connector			
Pin	Name	I/O	Description
1	ALM-	O	<u>Alarm Signal:</u> OC output signal, activated when one of the following protection is activated: over-voltage and over current error. They can sink or source MAX 8 mA current at 24 V, respectively 200 mW. The impedance between ALM+ and ALM- is high for normal operation and becomes low when any protection is activated.
2	ALM+	O	
3	PED-	O	<u>In-position Signal:</u> OC output signal, activated when actual motor position reaches to target position. This port can sink or source MAX 8 mA current at 24 V, respectively 200 mW. The impedance between PED+ and PED- is high for normal operation and becomes low when the target position is reached.
4	PED+	O	
5	ENA-	I	<u>Enable signal:</u> This signal is used for enabling/disabling the drive board. By default, high level (NPN control signal) for enabling the drive board and low level for disabling the drive board. It is usually left UNCONNECTED (ENABLED). Please note that the PNP and Differential control signals are on the contrary, namely Low level for enabling.
6	ENA+	I	
7	DIR-	I	<u>Direction Signal:</u> In single-pulse mode, this signal has low/high voltage levels, representing two directions of motor rotation. For reliable motion response, DIR signal should be ahead of PUL signal by 5 µs at least. 3.5 - 24 V for DIR-HIGH, 0 - 0.5 V for DIR-LOW. Toggle DIP switch S6 to reverse motion direction (optional: SW5 ON Direction CW/CCW).
8	DIR+	I	
9	PUL-	I	<u>Pulse Signal:</u> In single pulse (pulse/direction) mode, this input represents pulse signal, active at each rising or falling edge (Software configurable). 3.5 - 24 V for PUL-HIGH, 0 - 0.5 V for PUL-LOW. For reliable response, pulse width should be longer than 2.5 µs for 200 kHz MAX input frequency (optional: SW5 ON Direction CW/CCW).
10	PUL+	I	

## iHSS(C)86

## Integrated Stepper Motors CL

RS232 Kommunikationsanschluß				
Pin	Name	Colors at the beige round cable	Colors at the grey flat cable	Description
1	NC	-	-	Not connected
2	RX	Brown-White	Yellow	RS232 Receive data
3	GND	Blue	Green	Ground
4	TX	Blue-White	Red	RS232 Transmit data
5	VCC	-	-	Power Supply 3.3 V to HISU. <u>Attention:</u> For PC software use, leave unconnected!

**Note 1:** The RS232 communication port is not isolated. Please use an isolated power supply for the iHSSXX when the PC's serial port is not isolated.

**Note 2:** Do not plug or unplug the connector when power is on.

### 11. DIP Switch Settings:

Pulses per revolution of the iHSSXX can be configured via DIP switch S1-S4 or by the tuning software. When all S1-S4 are at "ON" positions, the drive will take the setting set by the software. In this case a user can reconfigure via software to a value divisible by 50 between 200 and 50000 pulses. If any bit of S1-S4 is at "OFF" position, the integrated drive board will take micro step resolution setting determined by bit positions of S1-S4. Use the following table for their resolution settings via the DIP switches.

Pulses / Revolution	SW 1	SW 2	SW 3	SW 4
Software configured / Default	on	on	on	on
800	off	on	on	on
1600	on	off	on	on
3200	off	off	on	on
6400	on	on	off	on
12800	off	on	off	on
25600	on	off	off	on
51200	off	off	off	on
1000	on	on	on	off
2000	off	on	on	off
4000	on	off	on	off
5000	off	off	on	off
8000	on	on	off	off
10000	off	on	off	off
20000	on	off	off	off
40000	off	off	off	off

**SW 5:** With SW5 the pulse mode can be configured. OFF (off) stands for PUL/DIR mode. ON (on) for CW/CCW

**SW 6:** is used for setting the running direction, "off" means CCW, while "on" means CW.

**SW 7:** is used for PUL Filter Setting, "off" means Max. PUL frequency is 200 kHz, on means Max. PUL frequency is 100 kHz. Note: When the P22 parameter is 0, the pulse filtering degree is controlled by the SW7 pulse interference filtering dialling code, when set to other non-zero values, SW7 does not work.

**SW 8:** is used for PUL Smoothing Setting, "off" means switch off PUL Smoothing, "on" means switch on PUL Smoothing.

# iHSS(C)86 Integrated Stepper Motors CL

## 12. Fine Tuning:

Standard parameters are already set ex works. These standard parameter values are optimized and suitable for most industrial applications. In most cases it is not necessary to change them. However, if you want to optimize the performance for your application, the software can be used to adjust these parameters.

## 13. Typical Connections:

Connection to Common Anode:

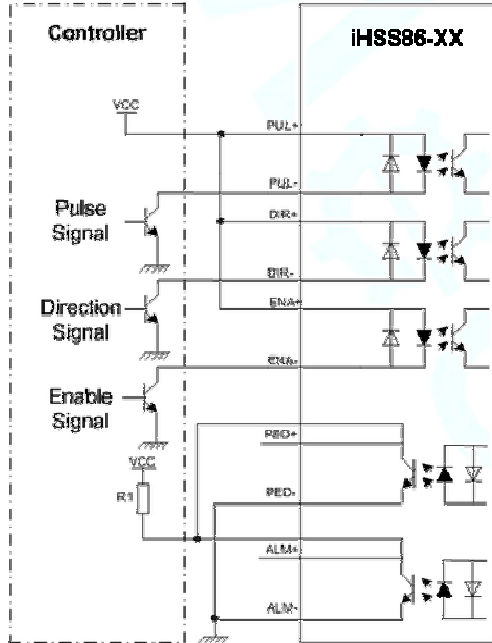

Connection to Common Cathode:

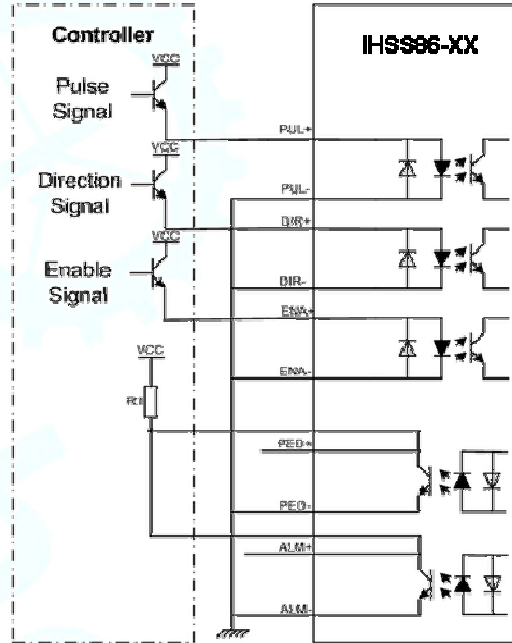

Connection to Differential Signal:

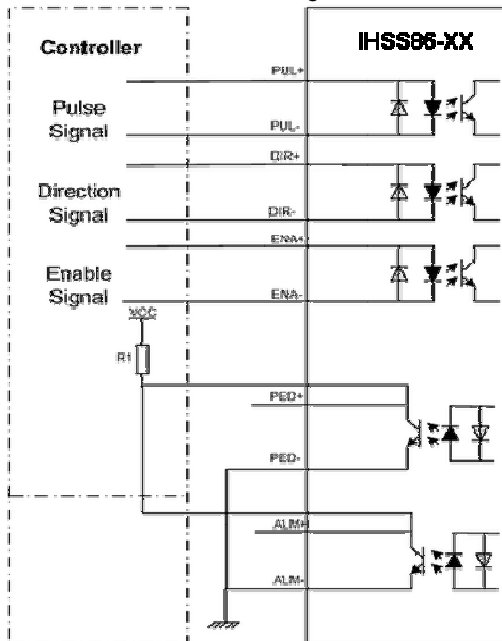

## 14. RS232 Communication Cable Connections:

**Note 1:** The RS232 communication port is not isolated. Please use a galvanic isolated power supply for the iHSS86-XX when the PC's serial port is not isolated.

**Note 2:** Do not plug or unplug the connector when power is on.

Definition		Remark
RX	○	Receive Data
GND	○	Power Ground
TX	○	Transmit Data
OR		
NC	○	Reserved
RX	○	Receive Data
GND	○	Power Ground
TX	○	Transmit Data
VCC	○	Power Supply to HISU

R1: to be selected depending on VCC; recommendation between 3 - 5 kΩ, since the OC ports switch max. 200 mW.