

DM556EU

Stepper Motor Driver

**Digital Driver
Model DM556EU**

Digital Technology, max. 50 VDC/ 5.6 A

Product Description:

The DM556EU is a digital stepper drive with simple design and easy setup. By implementing Leadshine's advanced stepper control technology, this stepper drive is able to power 2 phase and 4 phase stepper motors smoothly with optimal torque and low motor heating & noise. Its operating voltage is 20 - 50 VDC and it can output up to 4.2 A current. All the micro step and output current are done via DIP switches. Therefore, the DM556EU is an ideal choice for applications requiring simple step & direction control of NEMA 23, 24, and 34 stepper motors.

Features:

- Anti-Resonance for optimal torque, extra smooth motion, low motor heating and noise
- Motor auto-identification and parameter auto-configuration for optimal torque for a wide range of motors
- Step & direction (PUL/ DIR) control
- Multi-Stepping for smooth motor movement
- Optically isolated inputs
- Input voltage 20 - 50 VDC
- 16 selectable micro-step resolutions of 400 - 25,600 via DIP switches
- 8 selectable output current settings of 1.8 - 5.6 A via DIP switches
- Smooth motor start-up without "jump"
- Pulse input frequency up to 200 kHz.
- Automatic idle-current reduction
- Protections for over-voltage and over-current

Electrical Specifications:

Parameters	Min	Typ.	Max	Unit
Output current	1.8	-	5.6 (4.0 RMS)	A
Supply voltage	20	24 - 48	50	VDC
Logic signal current	7	10	16	mA
Pulse input frequency	0	-	200	kHz
Minimal pulse width	2.5			µs
Minimal direction setup	5.0			µs
Insulation resistance	500			MΩ

Further Specifications:

Parameters	Min	Typ.	Max
Microsteps / 1,8 °	400		25,600
Pulse/ Direction (PUL/ DIR)		X	
NEMA sizes	23		34
Motor type Mecheltron	57BYGH-XXX		86BYGH-XXX

DM556EU

Stepper Motor Driver



Digital Driver
Model DM556EU

Mechanical Specifications:

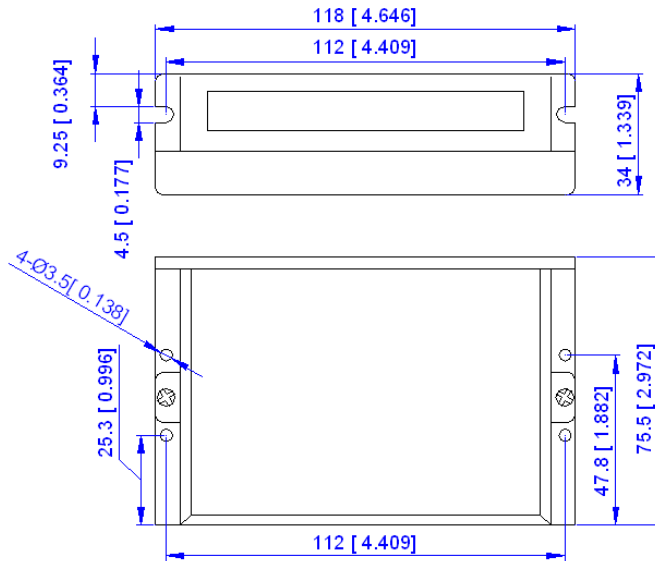

Unit: mm [inch]

Applications:

Suitable for a wide range of stepper motors of NEMA sizes 23, 24 and 34 (57 x 57 mm to 86 x 86 mm). It can be used in various kinds of machines, such as X-Y tables, engraving machines, labelling machines, laser cutters, pick-place devices, and so on. Particularly well suited for applications where low noise levels, less heat development, high speed and high precision are desired.

Typical Connection Schematic:

A typical system consists of stepper motor, stepper motor driver, power supply and controller. The following image shows a typical connection schematic:

