

User Manual

DM542E

2-Phase Digital Stepper Drive



Revision 1.0

©2016 China Leadshine Technology Co., Ltd.

Address: Floor 11, Block A3, Nanshan iPark, Xueyuan Avenue 1001, Shenzhen, Guangdong, 518055, China

Tel: (86)755-26409254

Fax: (86)755-26402718

Web: www.leadshine.com

Sales: sales@leadshine.com

Support: tech@leadshine.com

Notice

Read this manual carefully before any assembling and using. Incorrect handling of products in this manual can result in injury and damage to persons and machinery. Strictly adhere to the technical information regarding installation requirements.

This manual is not for use or disclosure outside of Leadshine except under permission. All rights are reserved. No part of this manual shall be reproduced, stored in retrieval form, or transmitted by any means, electronic, mechanical, photocopying, recording, or otherwise without approval from Leadshine. While every precaution has been taken in the preparation of the book, Leadshine assumes no responsibility for errors or omissions. Neither is any liability assumed for damages resulting from the use of the information contained herein.

This document is proprietary information of Leadshine that is furnished for customer use ONLY. Information in this document is subject to change without notice and does not represent a commitment on the part of Leadshine. Therefore, information contained in this manual may be updated from time-to-time due to product improvements, etc., and may not conform in every respect to former issues.

Record of Revisions

Revision	Date	Description of Release
<i>1.0</i>	<i>Dec, 2016</i>	<i>Initial Release</i>

Table of Contents

1. Introductions	1
1.1 Features.....	1
1.2 Applications	1
2. Specifications	1
2.1 Electrical Specifications	1
2.2 Environment	2
2.3 Mechanical Specifications	2
2.4 Elimination of Heat.....	2
3. Connection Pin Assignments and LED Indication	3
3.1 Connector P1 Configurations.....	3
3.2 Connector P2 Configurations.....	3
3.3 LED Light Indication.....	4
4. Control Signal Connector (P1) Interface	4
5. Motor Connection	4
5.1 Connections of 4-lead Motor	4
5.2 Connections of 6-lead Motor	4
5.2.1 Half Coil Configuration	5
5.2.2 Full Coil Configuration	5
5.3 Connections of 8-lead Motor	5
5.3.1 Series Connection	5
5.3.2 Parallel Connection	6
6. Power Supply Selection	6
6.1 Regulated or Unregulated Power Supply.....	6
6.2 Power Supply Sharing	6
6.3 Selecting Supply Voltage.....	6
7. DIP Switch Configurations	7
7.1 Microstep Resolution Configurations	7
7.2 Current Configurations	7
7.2.1 Dynamic Current Configurations	8
7.2.2 Standstill Current Configuration	8
7.3 Automatic Motor Matching & Self Configuration.....	8
8. Wiring Notes	8
9. Typical Connection	9
10. Sequence Chart of Control Signals	9
11. Protection Functions	10
12. Troubleshooting	11
13. Warranty	12
14. Contact Us	12

1. Introductions

The DM542E is a digital stepper drive with simple design and easy setup. By implementing Leadshine advanced stepper control technology, this stepper drive is able to power 2-phase and 4 phase stepper motors smoothly with optimal torque and low motor heating & noise. Its operating voltage is 20-50VDC and it can output up to 4.2A current. All the micro step and output current are done via DIP switches. Therefore, the DM542E are ideal choices for applications requiring simple step & direction control of NEMA 17, 23, and 24 stepper motors.

1.1 Features

- Anti-Resonance for optimal torque, extra smooth motion, low motor heating and noise
- Motor auto-identification and parameter auto-configuration for optimal torque from wide-range motors
- Step & direction (PUL/DIR) control
- Multi-Stepping for smooth motor movement
- TTL compatible and optically isolated inputs
- Input voltage 20-50VDC
- 16 selectable micro-step resolutions of 400-25,600 via DIP switches
- 8 selectable output current settings of 1.0 – 4.2A via DIP switches
- Soft-start with no “jump” when powered on
- Pulse input frequency up to 200 KHz.
- Automatic idle-current reduction
- Protections for over-voltage and over-current

1.2 Applications

The DM542E stepper drive are designed to power 2 phase (1.8°) or 4-phase (0.9°) NEMA 17, 23, and 24 hybrid stepper motors. It can be easily adopted in many industries (CNC, medical, automation, packaging...), such as X-Y tables, engraving machines, labeling machines, mills, plasma, laser cutters, pick and place devices, and so on. Its excellent performance, simple design, and easy setup make it ideal for many step & direction control type applications.

2. Specifications

2.1 Electrical Specifications

Parameters	DM542E			
	Min	Typical	Max	Unit
Output Current	1.0	-	4.2 (3.0 RMS)	A
Supply Voltage	20	24 - 48	50	VDC
Logic signal current	7	10	16	mA
Pulse input frequency	0	-	200	kHz
Minimal pulse width	2.5	-	-	μS
Minimal direction setup	5.0	-	-	μS
Isolation resistance	500			MΩ

2.2 Environment

Cooling	Natural Cooling or Forced cooling	
Operating Environment	Environment	Avoid dust, oil fog and corrosive gases
	Ambient Temperature	0°C — 65°C (32°F - 149°F)
	Humidity	40%RH—90%RH
	Operating Temperature	0°C — 50°C (32°F - 122°F)
	Vibration	10-50Hz / 0.15mm
Storage Temperature	-20°C — 65°C (-4°F - 149°F)	
Weight	Approx. 227g (8 oz)	

2.3 Mechanical Specifications

(unit: mm [1inch=25.4mm])

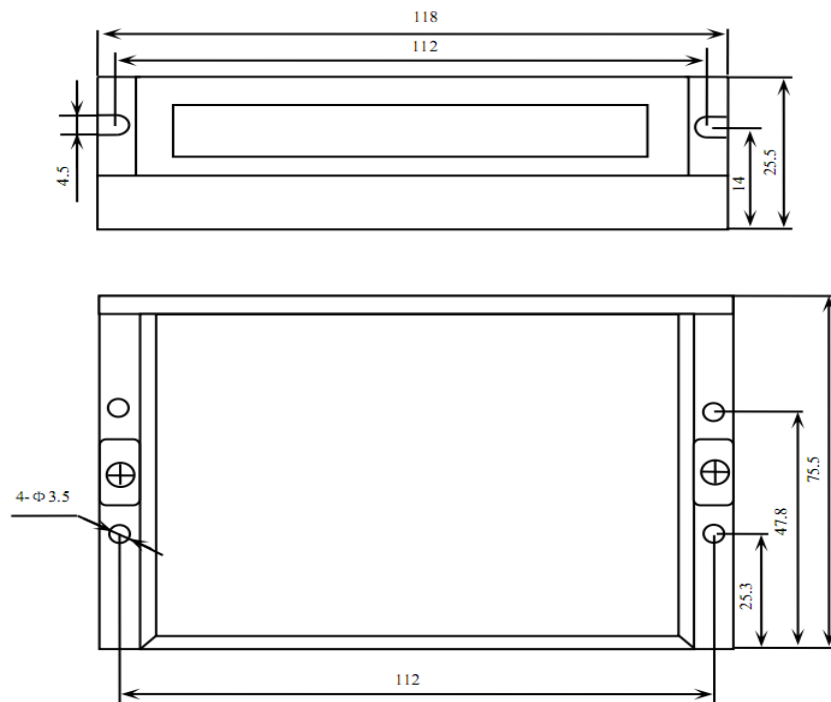

Figure 1: Mechanical specifications

*** Side mounting recommended for better heat dissipation**

2.4 Elimination of Heat

- DM542E reliable working temperature should be < 60°C (140°F)
- It is recommended to use automatic idle-current mode to reduce motor heating. That means set the SW4 pin of DIP switch at “OFF” position.
- It is recommended to mount the drive vertically to maximize heat sink area. Use forced cooling method to cool if necessary.

3. Connection Pin Assignments and LED Indication

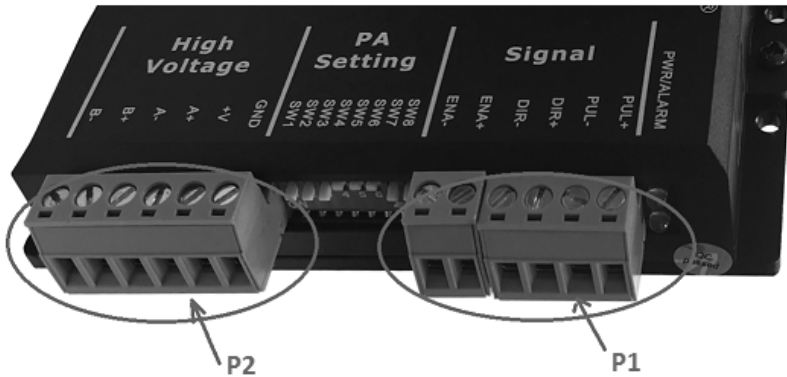

The DM542E has two connector blocks P1&P2 (see above picture). P1 is for control signals connections, and P2 is for power and motor connections. The following tables are brief descriptions of the two connectors. More detailed descriptions of the pins and related issues are presented in section 4, 5, 9.

3.1 Connector P1 Configurations

Pin Function	Details
PUL+	<u>Pulse signal:</u> Pulse active at rising edge; 4-5V when PUL-HIGH, 0-0.5V when PUL-LOW. Minimal pulse width of 2.5 μ s. Add a resistor for current-limiting at +12V or +24V input logic voltage (1K for +12V, 2k for +24V). The same as DIR and ENA signals.
PUL-	
DIR+	<u>DIR signal:</u> This signal has low/high voltage levels to represent two directions of motor rotation.. Minimal direction setup time of 5 μ s. Also swapping the connection of two wires of a coil (e.g. A+ and A-) to the drive will reverse motor direction.
DIR-	
ENA+	<u>Enable signal:</u> This signal is used for enabling/disabling the drive. High level +5V (NPN control signal) for enabling the drive and low level for disabling the drive. PNP and Differential control signals are on the contrary, namely Low level for enabling. By default it is left UNCONNECTED (ENABLED) .
ENA-	



Notes: (1) shielding control signal wires is suggested; (2) To avoid interference, don't tie PUL/DIR control signal and motor wires together

3.2 Connector P2 Configurations

Pin Function	Details
GND	Power supply ground connection.
+V	Power supply positive connection. Suggest 24-48VDC power supply voltage
A+, A-	Motor Phase A connections. Connect motor A+ wire to A+ Pin; motor A- wire to A-
B+, B-	Motor Phase B connections. Connect motor B+ wire to B+ Pin; motor B- wire to B-



Warning: Don't plug or unplug the P1 & P2 terminal block to avoid drive damage or injury when DM542E is powered on.

3.3 LED Light Indication

There are two LED lights for DM542E. The GREEN one is the power indicator which will be always on generally. The RED one is a protection indicator which will flash 1-2 times in a 3-second period, when protection enabled for a DM542E. Different number of flashes indicates different protection type (read section 11 for detail).

4. Control Signal Connector (P1) Interface

The DM542E can accept differential and single-ended inputs (including open-collector and PNP output). The DM542E has 3 optically isolated logic inputs which are located on connector P1 to accept line drive control signals. These inputs are isolated to minimize or eliminate electrical noises coupled with the drive control signals. Recommend using line drive control signals to increase noise immunity for the drive in interference environments. In the following figures, connections to open-collector and PNP signals are illustrated.

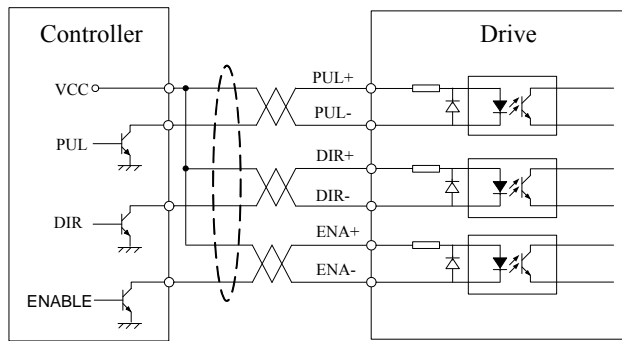

Figure 2: Connections to open-collector signal (common-anode)

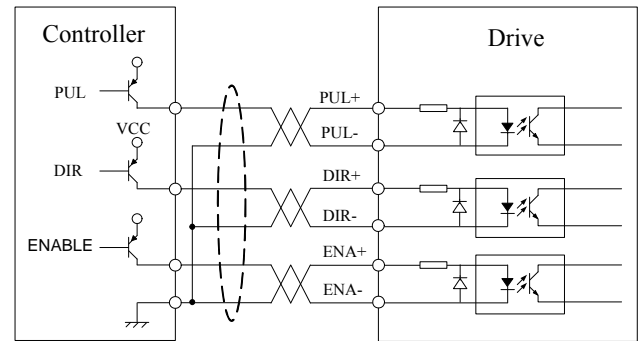

Figure 3: Connections to PNP signal (common-cathode)

5. Motor Connection

The DM542E can drive 2-phase and 4-phase bipolar hybrid stepper motors with 4, 6, or 8 wires.

5.1 Connections of 4-lead Motor

The 4 lead motors are the least flexible and easy to connect. And the Speed – torque of motor depends on winding inductance. The output current from drive that is multiply the specified phase current by 1.4 to determine the peak output current.

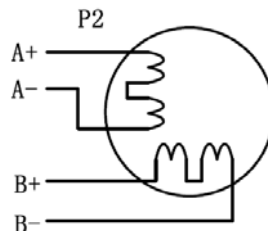

Figure 4: 4-lead Motor Connections

5.2 Connections of 6-lead Motor

Like 8 lead stepping motors, 6 lead motors have two configurations available for high speed or high torque operations. The higher speed configuration, or half coil, is described, because it uses one half of the motor's inductor windings. The higher torque configuration, or full coil, uses the full coil windings.

5.2.1 Half Coil Configuration

As previously stated, the half coil configuration uses 50% of the motor phase windings. This gives lower inductance, hence, lower torque output. Like the parallel connection of 8 lead motor, the torque output will be more stable at higher speeds. This configuration is also referred to as half chopper. In setting the drive output current multiply the specified per phase (or unipolar) current rating by 1.4 to determine the peak output current.

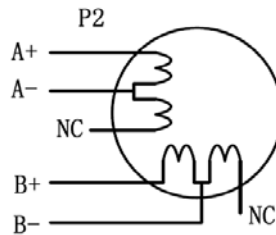

Figure 5: 6-lead motor half coil (higher speed) connections

5.2.2 Full Coil Configuration

The full coil configuration on a six lead motor should be used in applications where higher torque at lower speed is desired. This configuration is also referred to as full copper. In full coil mode, the motors should be run at only 70% of their rated current to prevent overheating.

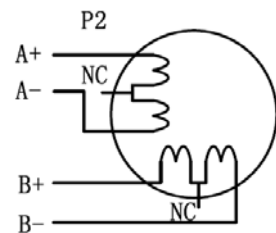

Figure 6: 6-lead motor full coil (higher torque) connections

5.3 Connections of 8-lead Motor

8 lead motors offer a high degree of flexibility to the system designer in that they may be connected in series or parallel, thus satisfying a wide range of applications.

5.3.1 Series Connection

A series motor configuration would typically be used in applications where a higher torque at lower speed is required. Because this configuration has the most inductance, the performance will start to degrade at higher speed. In series mode, the motors should also be run at only 70% of their rated current to prevent overheating.

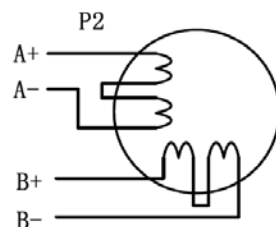

Figure 7: 8-lead motor series connections

5.3.2 Parallel Connection

An 8 lead motor in a parallel configuration offers a more stable, but lower torque at lower speeds. But because of the lower inductance, there will be higher torque at higher speeds. Multiply the phase (or unipolar) current rating by 1.96, or the bipolar current rating by 1.4, to determine the peak output current.

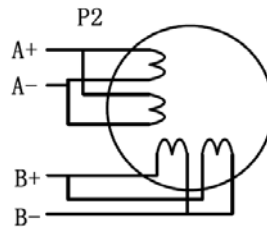

Figure 8: 8-lead motor parallel connections

6. Power Supply Selection

The DM542E can power medium and small size stepping motors (frame size from NEMA17 to 24) made by Leadshine or other motor manufacturers. To get good driving performances, it is important to select supply voltage and output current properly. Generally speaking, supply voltage determines the high speed performance of the motor, while output current determines the output torque of the driven motor (particularly at lower speed). Higher supply voltage will allow higher motor speed to be achieved, at the price of more noise and heating. If the motion speed requirement is low, it's better to use lower supply voltage to decrease noise, heating and improve reliability.

6.1 Regulated or Unregulated Power Supply

Both regulated and unregulated power supplies can be used to supply the drive. However, unregulated power supplies are preferred due to their ability to withstand current surge and fast response for current change. If you prefer to a regulated power supply, it is suggested to choose such a power supply specially designed for stepper/servo controls such as Leadshine RPS series (<http://www.leadshine.com/producttypes.aspx?producttype=regulated-switching>). Or, in the case when only normal switching power supplies are available, it is important to use "OVERSIZE" high current output rating power supplies (for example, using a 4A power supply for 3A stepper motor) to avoid problems such as current clamp. On the other hand, if unregulated supply is used, one may use a power supply of lower current rating than that of motor (typically 50%~70% of motor current). The reason is that the drive draws current from the power supply capacitor of the unregulated supply only during the ON duration of the PWM cycle, but not during the OFF duration. Therefore, the average current withdrawn from power supply is considerably less than motor current. For example, two 3A motors can be well supplied by one power supply of 4A rating.

6.2 Power Supply Sharing

Multiple DM542E drives can share one power supply to reduce cost, if that power supply has enough power capacity. To avoid cross interference, connect each stepper drive directly to the shared power supply separately. To avoid cross interference, DO NOT daisy-chain connect the power supply input pins of the Drivers. Instead connect them to power supply separately.

6.3 Selecting Supply Voltage

The DM542E is designed to operate within +20 - +50VDC voltage input. When selecting a power supply, besides

voltage from the power supply power line voltage fluctuation and back EMF voltage generated during motor deceleration needs also to be taken into account. Ideally it is suggested to use a power supply with the output range of +24 - +48 VDC, leaving room for power line voltage fluctuation and back-EMF.

Higher supply voltage can increase motor torque at higher speeds, thus helpful for avoiding losing steps. However, higher voltage may cause bigger motor vibration at lower speed, and it may also cause over-voltage protection or even drive damage. Therefore, it is suggested to choose only sufficiently high supply voltage for intended applications.

7. DIP Switch Configurations

This drive uses an 8-bit DIP switch to set microstep resolution, and motor operating current, as shown below:

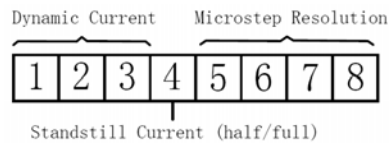

7.1 Microstep Resolution Configurations

Microstep resolution is set by SW5, 6, 7, 8 of the DIP switches as shown in the following table:

Microstep	Steps/rev.(for 1.8°motor)	SW5	SW6	SW7	SW8
2	400	OFF	ON	ON	ON
4	800	ON	OFF	ON	ON
8	1600	OFF	OFF	ON	ON
16	3200	ON	ON	OFF	ON
32	6400	OFF	ON	OFF	ON
64	12800	ON	OFF	OFF	ON
128	25600	OFF	OFF	OFF	ON
5	1000	ON	ON	ON	OFF
10	2000	OFF	ON	ON	OFF
20	4000	ON	OFF	ON	OFF
25	5000	OFF	OFF	ON	OFF
40	8000	ON	ON	OFF	OFF
50	10000	OFF	ON	OFF	OFF
100	20000	ON	OFF	OFF	OFF
125	25000	OFF	OFF	OFF	OFF

7.2 Current Configurations

For a given motor, higher drive current will make the motor to output more torque, but at the same time causes more heating in the motor and drive. Therefore, output current is generally set to be such that the motor will not overheat for long time operation. Since parallel and serial connections of motor coils will significantly change resulting inductance and resistance, it is therefore important to set drive output current depending on motor phase current, motor leads and connection methods. Phase current rating supplied by motor manufacturer is important in selecting drive current,

however the selection also depends on leads and connections.

The first three bits (SW1, 2, 3) of the DIP switch are used to set the dynamic current. Select a setting closest to your motor's required current.

7.2.1 Dynamic Current Configurations

Peak Current	RMS Current	SW1	SW2	SW3
1.00A	0.71A	ON	ON	ON
1.46A	1.04A	OFF	ON	ON
1.91A	1.36A	ON	OFF	ON
2.37A	1.69A	OFF	OFF	ON
2.84A	2.03A	ON	ON	OFF
3.31A	2.36A	OFF	ON	OFF
3.76A	2.69A	ON	OFF	OFF
4.20A	3.00A	OFF	OFF	OFF

Notes: Due to motor inductance, the actual current in the coil may be smaller than the dynamic current setting, particularly under high speed condition.

7.2.2 Standstill Current Configuration

SW4 is used to set motor idle current percentage. At OFF position it means the standstill current is set to be 50% of the selected output current. At ON position it means standstill current is set to be the same as the selected dynamic current.

The current automatically reduced to 50% of the selected dynamic current 0.4 second after the last pulse.

7.3 Automatic Motor Matching & Self Configuration

When powered on a DM542E will automatically configure itself with the best settings to match the driven stepper motor for optimal performance. No action is needed.

8. Wiring Notes

- In order to improve anti-interference performance of the drive, it is recommended to use twisted pair shield cable.
- To prevent noise incurred in PUL/DIR signal, pulse/direction signal wires and motor wires should not be tied up together. It is better to separate them by at least 10 cm, otherwise the disturbing signals generated by motor will easily disturb pulse direction signals, causing motor position error, system instability and other failures.
- If only one power supply serves multiple DM542E drives, separately connecting the drives to the power supply is recommended instead of daisy-chaining.
- It is prohibited to pull and plug connector P2 while the drive is powered ON, because there is high current flowing through motor coils (even when motor is at standstill). Pulling or plugging connector P2 with power on will cause extremely high back-EMF voltage surge, which may damage the drive.

9. Typical Connection

A complete stepping system should include stepping motor, stepping drive, power supply and controller (pulse generator). A typical connection is shown as figure 9.

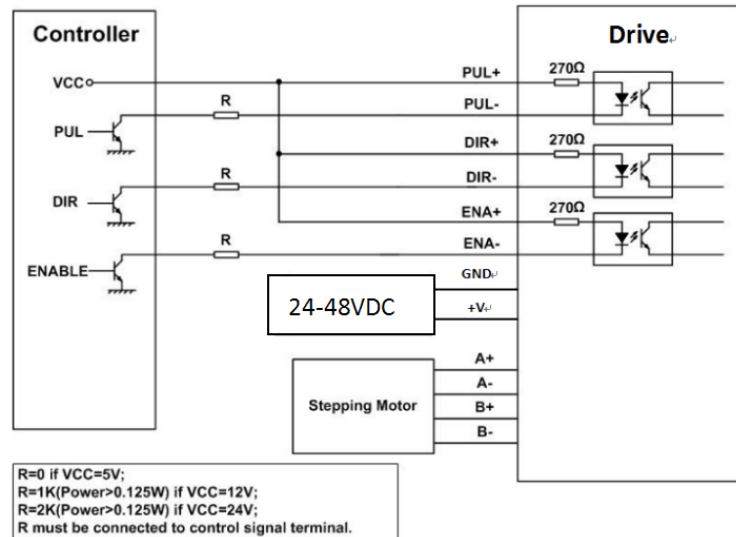

Figure 9: Typical connection

10. Sequence Chart of Control Signals

In order to avoid some fault operations and deviations, PUL, DIR and ENA should abide by some rules, shown as following diagram:

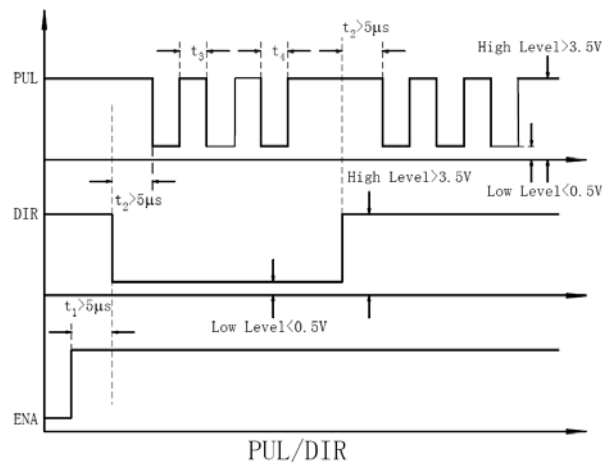





Figure 10: Sequence chart of control signals

Remark:

- t_1 : ENA must be ahead of DIR by at least $5\mu s$. Usually, ENA+ and ENA- are NC (not connected). See “Connector P1 Configurations” for more information.
- t_2 : DIR must be ahead of PUL effective edge by $5\mu s$ to ensure correct direction;
- t_3 : Pulse width not less than $2.5\mu s$;
- t_4 : Low level width not less than $2.5\mu s$.

11. Protection Functions

To improve reliability, the drive incorporates some built-in protections features.

Priority	Time(s) of Blink	Sequence wave of red LED	Description
1st	1		Over-current protection activated when peak current exceeds the limit.
2nd	2		Over-voltage protection activated when drive working voltage is greater than 60VDC
3rd	3		Reserved.

When above protections are active, the motor shaft will be free or the red LED blinks. Reset the drive by repowering it to make it function properly after removing above problems.

12. Troubleshooting

In the event that your drive doesn't operate properly, the first step is to identify whether the problem is electrical or mechanical in nature. The next step is to isolate the system component that is causing the problem. As part of this process you may have to disconnect the individual components that make up your system and verify that they operate independently. It is important to document each step in the troubleshooting process. You may need this documentation to refer back to at a later date, and these details will greatly assist our Technical Support staff in determining the problem should you need assistance.

Many of the problems that affect motion control systems can be traced to electrical noise, controller software errors, or mistake in wiring.

Problem Symptoms and Possible Causes

Symptoms	Possible Problems
Motor is not rotating	No power
	Microstep resolution setting is wrong
	DIP switch current setting is wrong
	Fault condition exists
	The drive is disabled
Motor rotates in the wrong direction	Motor phases may be connected in reverse
The drive in fault	DIP switch current setting is wrong
	Something wrong with motor coil
Erratic motor motion	Control signal is too weak
	Control signal is interfered
	Wrong motor connection
	Something wrong with motor coil
	Current setting is too small, losing steps
Motor stalls during acceleration	Current setting is too small
	Motor is undersized for the application
	Acceleration is set too high
	Power supply voltage too low
Excessive motor and drive heating	Inadequate heat sinking / cooling
	Automatic current reduction function not being utilized
	Current is set too high

13. Warranty

Twelve Month Warranty

Leadshine Technology Co., Ltd. warrants its products against defects in materials and workmanship for a period of 12 months from shipment out of factory. During the warranty period, Leadshine will either, at its option, repair or replace products which proved to be defective.

Exclusions

The above warranty does not extend to any product damaged by reasons of improper or inadequate handlings by customer, improper or inadequate customer wirings, unauthorized modification or misuse, or operation beyond the electrical specifications of the product and/or operation beyond environmental specifications for the product.

Obtaining Warranty Service

To obtain warranty service, please contact your seller to obtain a returned material authorization number (RMA) before returning product for service.

Shipping Failed Products

If your product fail during the warranty period, please contact your seller for how and where to ship the failed product for warranty or repair services first, you can also e-mail customer service at tech@leadshine.com to obtain a returned material authorization number (RMA) before returning product for service. Please include a written description of the problem along with contact name and address.

14. Contact Us

China Headquarter

Address: Floor 11, Block A3, Nanshan iPark, Xueyuan Avenue 1001, Shenzhen, Guangdong, 518055, China

Web: <http://www.leadshine.com>

Sales Hot Line:

Tel: 86-755-2643 4369 (for All)

86-755-2641-7674 (for Asia, Australia, Africa areas)

86-755-2640-9254 (for Europe, America areas)

Fax: 86-755-2640-2718

Email: sales@leadshine.com.

Technical Support:

Tel: 86 755-2641-8447 and 86-755-2647-1129

Fax: 86-755-2640-2718

Email: tech@leadshine.com.

Leadshine U.S.A

Address: 26050 Towne Centre Dr. Foothill Ranch, CA 926 USA

Tel: 1-949-608-7270

Fax: 1-949-608-7298

Web: <http://www.leadshineusa.com>

Email: sales@leadshineusa.com and support@leadshineusa.com.