

SENSOR FUNCTIONS	
S1	Tool holder is hooked up correctly
S2	Collet is open
S3	Speed sensor 2 high/rev
S5	Piston in upper position

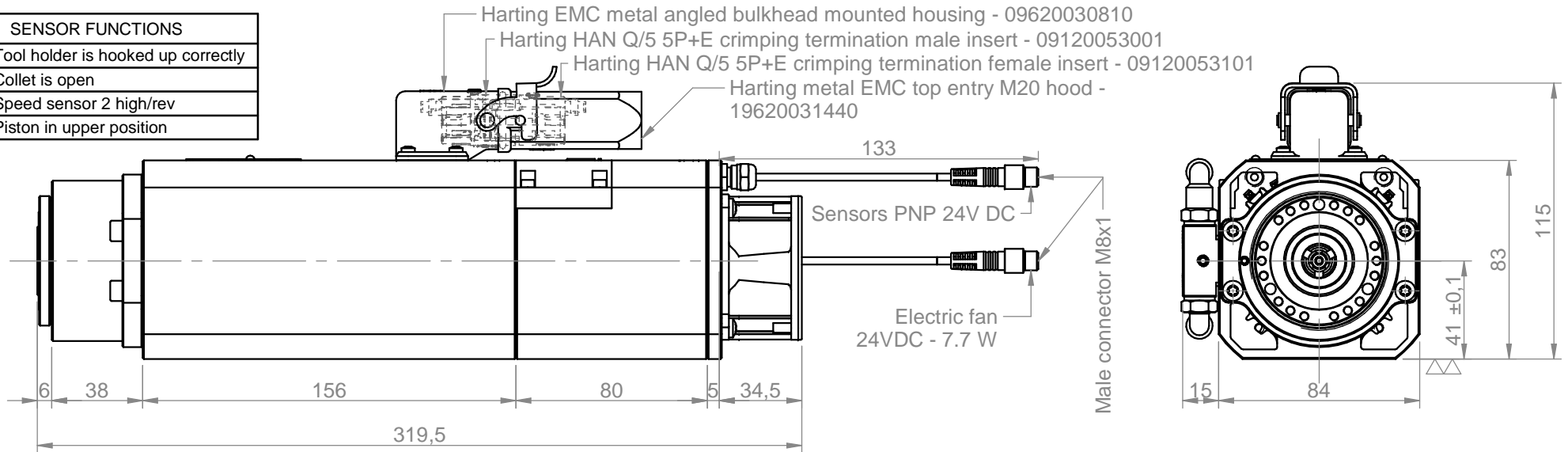

### PLUG CONNECTION

pin #1: PTC  
 pin #2: PTC  
 pin #3: U  
 pin #4: V  
 pin #5: W

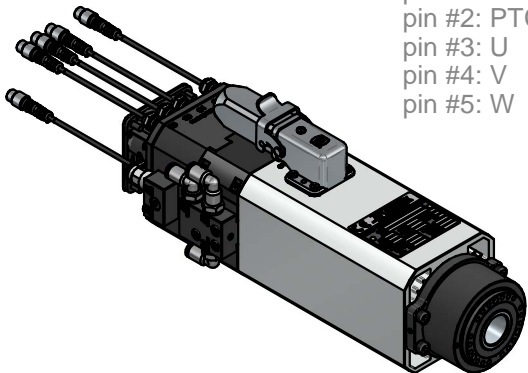

Power [kW]	Duty Cycle	Base speed [rpm]	Base freq. [Hz]	Base voltage Δ [V]	Absorb. Δ [A]	Base voltage Y [V]	Absorb. Y [A]	<p>Teknomotor S.r.l.          Via Argenege 31, I-32038 Quero Vas (BL)          www.teknomotor.com</p>
1.1	S6-60%	18000	300	220	4.3			
Min speed [rpm]		Max speed [rpm]	Max freq. [Hz]	Protection	Ins. Cl.	Part number on nameplate		Title <b>ATC41-A-DB-ISO20-SN</b>
6000		24000	400	IP54	F	COMTC410001		
Balancing according to ISO 1940 - G2.5 @ 24000 rpm		Balancing type		tool type full key	tool type half key	Peso / weight		Customer <b>Catalogo</b>
						5.77 kg		
rev. n°	description		date		signature		Drawing code	
00	Emissione		10/05/2017		D. Bottarel		COMTC410001	
drawn - date		approved - date	checked - date	sostituisce il		foglio / sheet	scala	
D. Bottarel - 10/05/2017		S. Perli - 10/05/2017	S. Perli - 10/05/2017	sostituito dal		1 / 1	n.d.	