

Ghiera serraggio  
GTS20 RH

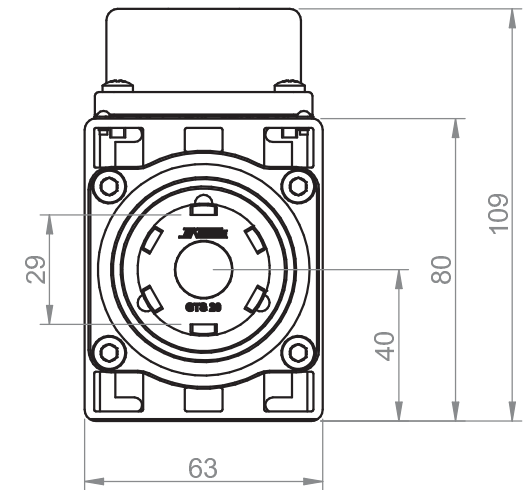
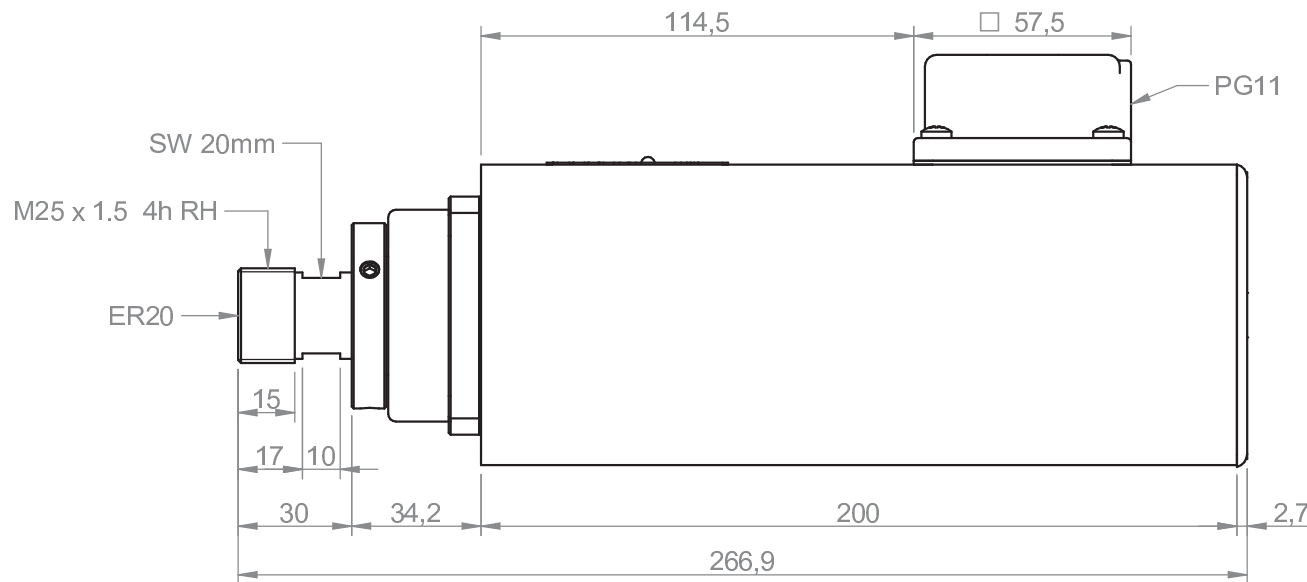
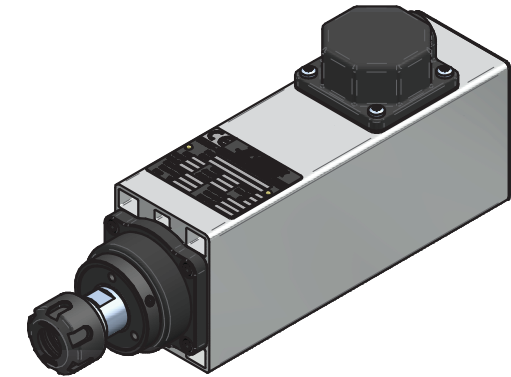
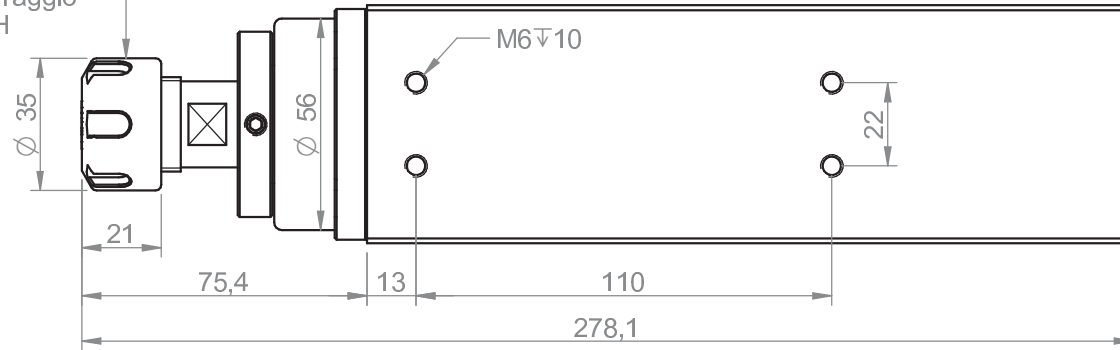

Power [kW]	Duty Cycle	Base speed [rpm]	Base freq. [Hz]	Base voltage Δ [V]	Base voltage Y [V]	Protection	Ins. Cl.	<b>TEKNOMOTOR</b>	
1.1	S6-60%	18000	300	220	380	IP54	F		
Min speed [rpm]		Max speed [rpm]	Max freq. [Hz]	Absorb. Δ [A]	Absorb. Y [A]	Part number on nameplate			
6000		24000	400	4.5	2.6	COM31400414			
Balancing: G2.5 - ISO 1940 @ maximum motor speed		Balancing type		∅ full key	∅ half key	Peso / weight			
						4.12 kg			
Tolleranze non quotate / unlisted tollerances: ±0.5mm Smussi non quotati / unlisted chamfers: ±0.5mm				$\nabla = 0.8 \nabla$	$\nabla = 3.2 \nabla$	$\nabla = 12.5 \nabla$	$\sim = \nabla$	Title	
								3140-C-DBS-P-ER20-RR-RH	
rev. n°	description			date	signature	Customer			
00	Emissione			21/02/2017	D. Bottarel	Catalogo			
						Drawing code	Drawing n°		
						COM31400414	5127		
drawn - date	approved - date	checked - date	sostituisce il		foglio / sheet	scala	A4		
E. Gaspari - 21/02/2017	S. Perli - 21/02/2017	S. Perli - 21/02/2017	sostituito dal		1 / 1	1:2			