

Ghiera serraggio  
GTS20 RH

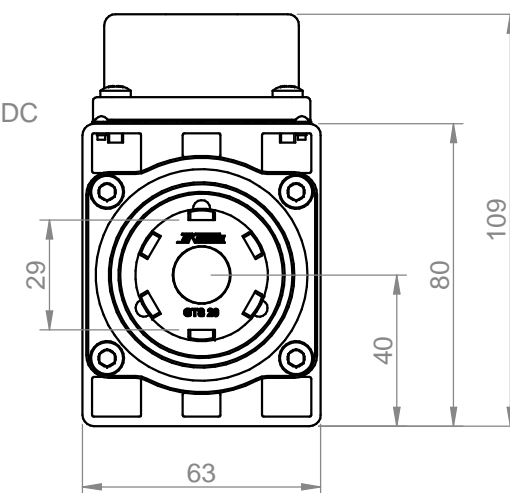
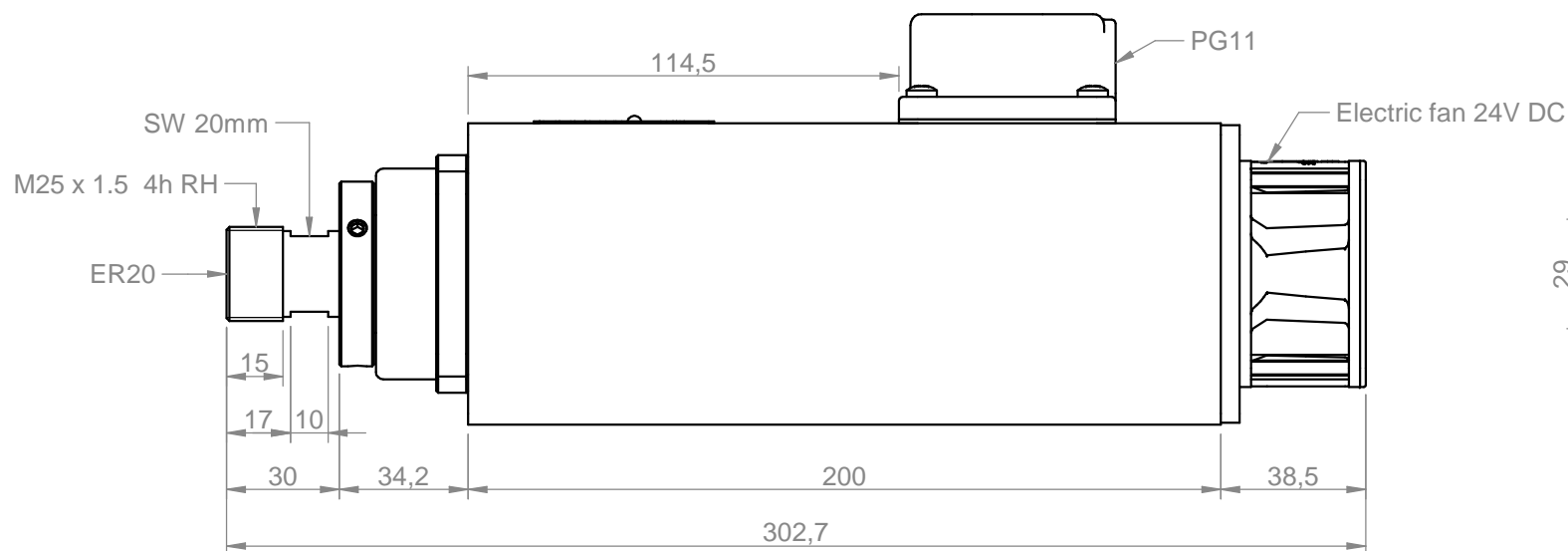
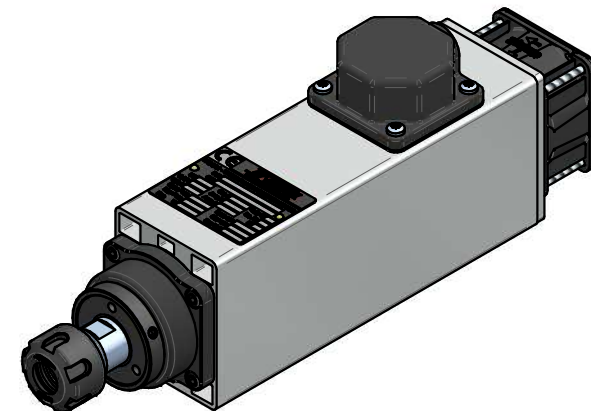
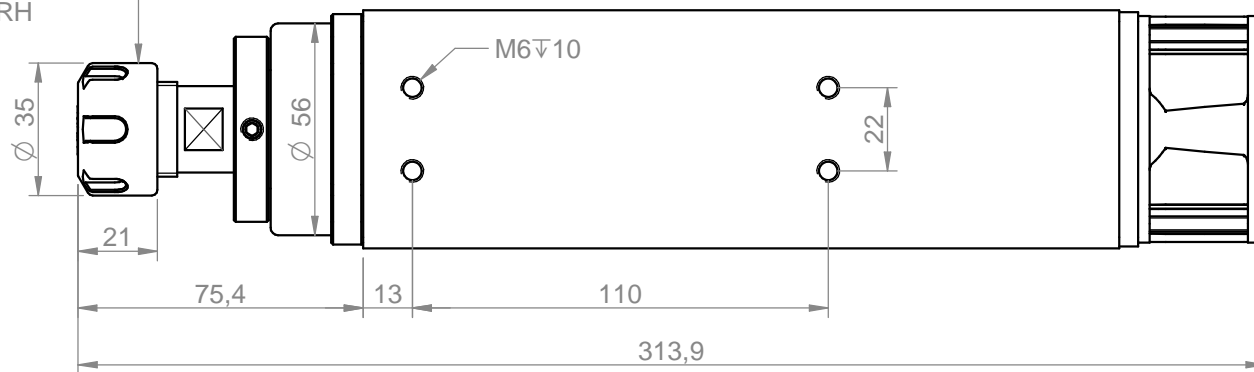

MOTOR WITH PTC 130°C

Power [kW] <b>0.73</b>	Duty Cycle <b>S1</b>	Base speed [rpm] <b>18000</b>	Base freq. [Hz] <b>300</b>	Base voltage Δ [V] <b>220</b>	Base voltage Y [V] <b>380</b>	Protection <b>IP54</b>	Ins. Cl. <b>F</b>
Min speed [rpm] <b>3000</b>		Max speed [rpm] <b>24000</b>	Max freq. [Hz] <b>400</b>	Absorb. Δ [A] <b>3.6</b>	Absorb. Y [A] <b>2.1</b>	Part number on nameplate <b>COM31400407</b>	
Balancing: G2.5 - ISO 1940 @ maximum motor speed		Balancing type		tool type full key	tool type half key	Peso / weight <b>4.07 kg</b>	
Tolleranze non quotate / unlisted tolerances: ±0.5mm Smussi non quotati / unlisted chamfers: ±0.5mm				$\nabla = 0.8 \nabla$	$\nabla = 3.2 \nabla$	$\nabla = 12.5 \nabla$	$\sim = \nabla$
rev. n° <b>00</b>	description <b>Emissione</b>			date <b>20/02/2017</b>	signature <b>D. Bottarel</b>		Title <b>3140-C-DBS-P-ER20-SV-RH</b>
Customer <b>Catalogo</b>						Drawing n° <b>5120</b>	
Drawing code <b>COM31400407</b>						Drawing n° <b>5120</b>	
drawn - date <b>E. Gaspari - 20/02/2017</b>	approved - date <b>S. Perli - 20/02/2017</b>	checked - date <b>S. Perli - 20/02/2017</b>	sostituisce il sostituito dal		foglio / sheet <b>1 / 1</b>	scala <b>1:2</b>	<b>A4</b>