

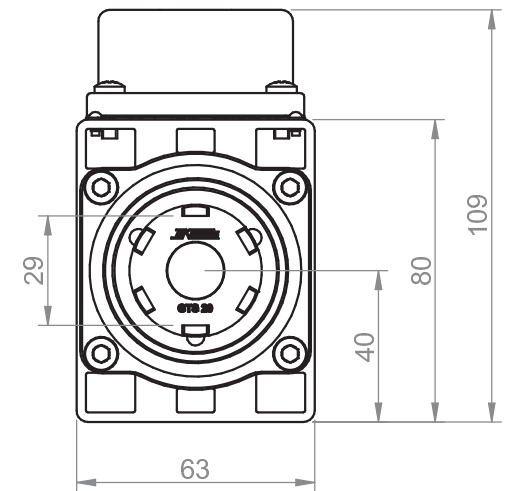

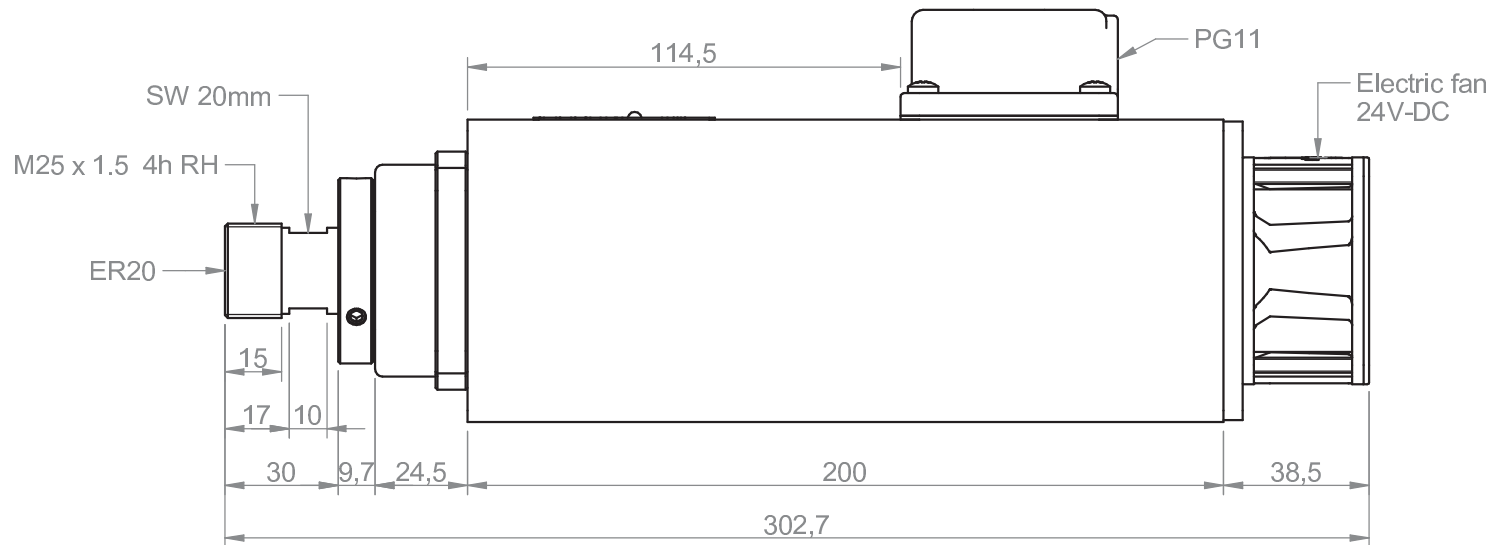

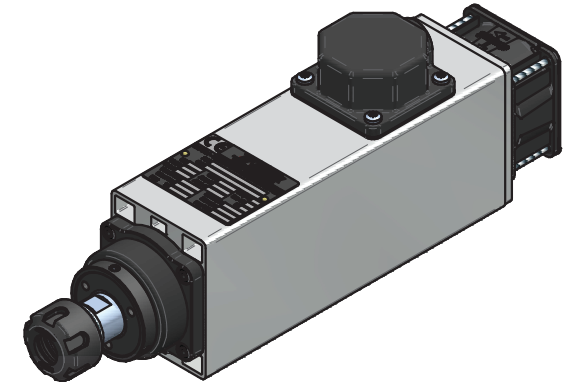

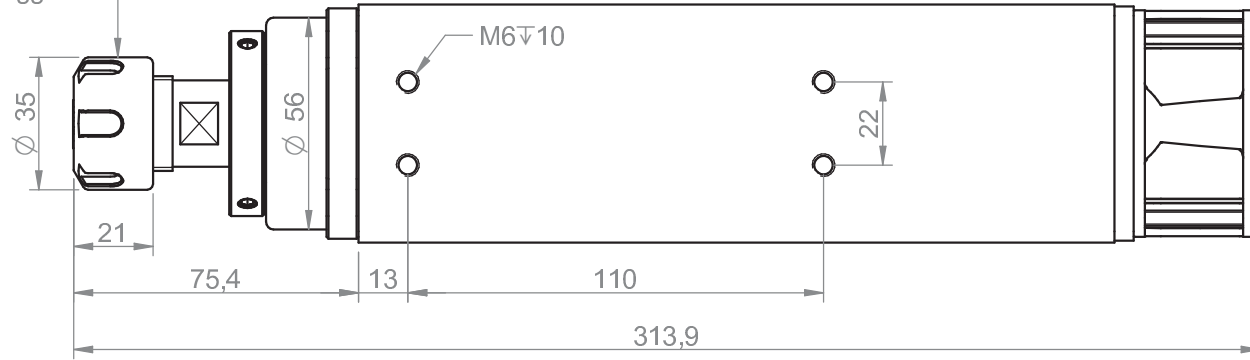

Ghiera serraggio
GTS20 RH



MOTOR WITH PTC THERMISTOR 130°C

Power [kW] 1.1	Duty Cycle S1	Base speed [rpm] 18000	Base freq. [Hz] 300	Base voltage Δ [V] 220	Base voltage Y [V] 380	Protection IP54	Ins. Cl. F	 <p>Teknomotor S.r.l. Via Argenegea 31, I-32038 Quero Vas (BL) www.teknomotor.com</p>
Min speed [rpm] 6000		Max speed [rpm] 24000	Max freq. [Hz] 400	Absorb. Δ [A] 4.5	Absorb. Y [A] 2.6	Part number on nameplate COM31400404		
Balancing: G2.5 - ISO 1940 @ maximum motor speed		Balancing type		 full key  half key	Peso / weight 4.29 kg		Title 3140-C-DBS-P-ER20-SV-RR-RH	
Tolleranze non quotate / unlisted tollerances: ±0.5mm Smussi non quotati / unlisted chamfers: ±0.5mm				 = 0.8  = 3.2  = 12.5  = ∅				
rev. n° 00	description Emissione			date 30/01/2017	signature D. Bottarel	Customer Catalogo		
						Drawing code COM31400404		Drawing n° 5056
drawn - date E. Gaspari - 30/01/2017	approved - date S. Perli - 30/01/2017	checked - date S. Perli - 30/01/2017	sostituisce il sostituito dal		foglio / sheet 1 / 1	scala 1:2	 A4	