

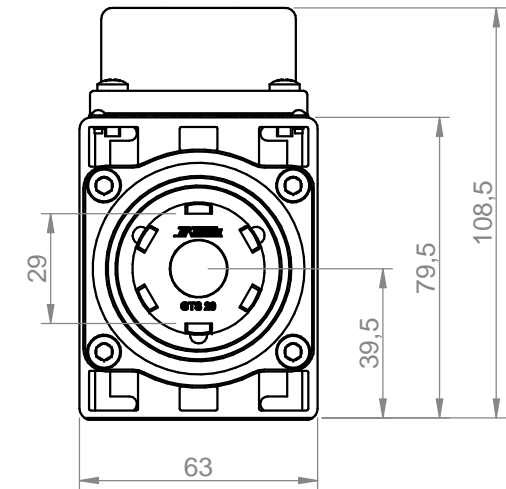

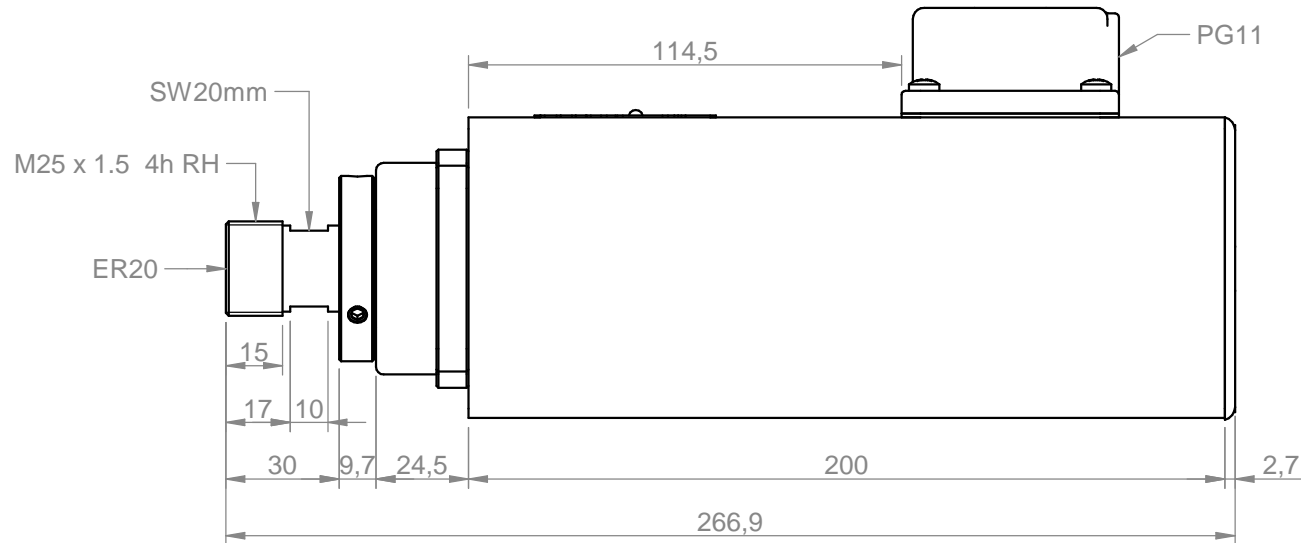

Ghiera serraggio  
GTS20 RH

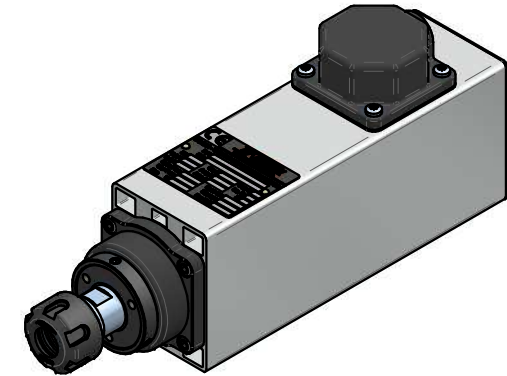
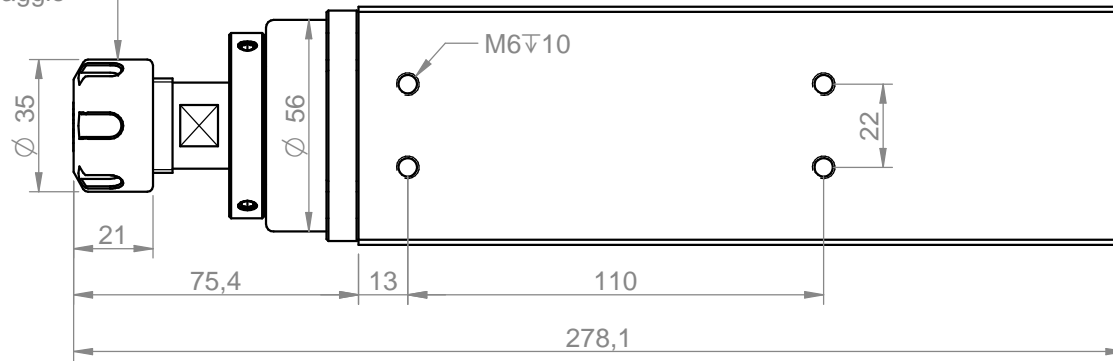

Power [kW] <b>0.73</b>	Duty Cycle <b>S1</b>	Base speed [rpm] <b>18000</b>	Base freq. [Hz] <b>300</b>	Base voltage Δ [V] <b>220</b>	Base voltage Y [V] <b>380</b>	Protection <b>IP54</b>	Ins. Cl. <b>F</b>	 <p>Teknomotor S.r.l. Via Argenege 31, I-32038 Quero Vas (BL) www.teknomotor.com</p>				
Min speed [rpm] <b>6000</b>		Max speed [rpm] <b>24000</b>	Max freq. [Hz] <b>400</b>	Absorb. Δ [A] <b>3.6</b>	Absorb. Y [A] <b>2.1</b>	Part number on nameplate <b>COM31400219</b>						
Balancing: G2.5 - ISO 1940 @ maximum motor speed		Balancing type		tool type full key 	tool type half key 	Peso / weight <b>3.90 kg</b>		Title <b>3140-C-DBS-P-ER20-RH</b>				
Tolleranze non quotate / unlisted tollerances: ±0.5mm Smussi non quotati / unlisted chamfers: ±0.5mm				$\nabla = 0.8 \nabla$	$\nabla = 3.2 \nabla$	$\nabla = 12.5 \nabla$	$\sim = \nabla$					
rev. n° <b>00</b>	description <b>Emissione</b>			date <b>21/04/2010</b>	signature <b>D. Bottarel</b>	Customer <b>Catalogo</b>						
drawing - date <b>D. Bottarel - 21/04/2010</b>						approved - date <b>S. Perli - 21/04/2010</b>		checked - date <b>S. Perli - 21/04/2010</b>	Drawing code <b>COM31400219</b>		Drawing n° <b>1701</b>	
sostituisce il sostituito dal				foglio / sheet <b>1 / 1</b>		scala <b>1:2</b>		